

2014

Novel Microwave Applicators Based on Zero-Order Mode Resonance for Hyperthermia Treatment of Cancer

David Vrba
Czech Technical University in Prague

Jan Vrba
Czech Technical University in Prague

Paul R. Stauffer
Thomas Jefferson University

Follow this and additional works at: <https://jdc.jefferson.edu/radoncfp>

 Part of the [Oncology Commons](#), and the [Radiology Commons](#)

[Let us know how access to this document benefits you](#)

Recommended Citation

2014 IEEE Benjamin Franklin Symposium on Microwave and Antenna Sub-systems

This Article is brought to you for free and open access by the Jefferson Digital Commons. The Jefferson Digital Commons is a service of Thomas Jefferson University's [Center for Teaching and Learning \(CTL\)](#). The Commons is a showcase for Jefferson books and journals, peer-reviewed scholarly publications, unique historical collections from the University archives, and teaching tools. The Jefferson Digital Commons allows researchers and interested readers anywhere in the world to learn about and keep up to date with Jefferson scholarship. This article has been accepted for inclusion in Department of Radiation Oncology Faculty Papers by an authorized administrator of the Jefferson Digital Commons. For more information, please contact: JeffersonDigitalCommons@jefferson.edu.

Novel Microwave Applicators Based on Zero-Order Mode Resonance for Hyperthermia Treatment of Cancer

David Vrba¹, Jan Vrba¹, Paul Stauffer²

¹Department of Biomedical Technology, Faculty of Biomedical Engineering, Czech Technical University in Prague, Zikova 4, 166 36 Prague, Czech Republic

²Radiation Oncology Dept., Thomas Jefferson University, Bodine Cancer Center Room G302A, 111 S. 11th. St. Philadelphia PA 19107

Abstract — In this paper, three novel microwave applicator prototypes based on zero-order mode resonators are proposed for use in hyperthermia treatment of cancer. The ability of all three applicators to homogeneously irradiate muscle tissue-equivalent phantoms is demonstrated with results of numerical simulations, and relative performance of the applicators is compared.

Index Terms — Microwave hyperthermia, zero-order mode resonator, metamaterial applicator, plane wave excitation.

I. INTRODUCTION

Based on previous research [1], it can be stated that metamaterial (MTM) Zeroth-Order mode resonators (ZOR) can provide improved thermotherapy for cancer in several ways, by improving the homogeneity of electromagnetic (EM) power absorption, the depth of EM wave penetration, and offering the possibility of either homogeneous treatment of very large areas or conversely focusing EM power into well-defined small areas [2].

New capabilities include, among others, the creation of electrically small applicators that can work without water filling. This could facilitate the delivery of microwave hyperthermia treatment simultaneous with 3D monitoring of temperature distribution in the patient with Magnetic Resonance (MR) thermal imaging.

Another advantage of MTM technology is that this phenomenon enables the creation of a special kind of resonator whose physical length is completely independent of the classical resonance condition (wavelength). This allows us to design the applicator with dimensions matching the clinical need and as a result of the spatial arrangement of MTM resonators we are able to radiate an almost perfect electromagnetic plane wave into the treated area. This improvement in wave propagation produces the advantage of optimizing homogeneity of power deposition within the target tissue region resulting in an improved temperature distribution throughout the treated area.

In this paper, three new geometries of microwave applicators based on zeroth-order mode resonators are proposed for hyperthermia cancer treatment. Each applicator was modeled using a well-proven commercial numerical simulator, COMSOL Multiphysics (COMSOL AB,

Stockholm, Sweden), and all three applicators are mutually compared with respect to the homogeneity of power deposition induced in numerical muscle tissue-equivalent phantoms. Relative performance of the applicators is compared.

II. NEW TYPES OF APPLICATORS

All three applicators are designed for use at 434 MHz and have similar working principle. Thanks to the excitation of zero-order mode, vectors of surface current density in all inductive parts of the proposed applicators show approximately the same magnitude and phase. The radiated contributions from the all inductive parts of the applicator are in good superposition as they exit the front aperture of the applicator and combine in phase in tissue. This allows the Huygens principle to be applied to describe the resulting EM field distribution in tissue. In Figs. 1-3, the inductive parts of the applicators are denoted in yellow, including the feedlines.

The first proposed applicator (Applicator 1), shown in Fig. 1, is based on micro-coplanar technology with four MTM unit cells. The micro-coplanar transmission line consists of signal and ground conductors. In this design a ground plane is used as well. The ground plane should suppress backside radiation of the applicator. The radiation characteristics are similar to microstrip patch type applicators. More detailed description of this structure can be found in [3]. The applicator is designed on FR4 substrate with height $h = 1.5\text{mm}$ and relative permittivity $\epsilon_r = 4.3$. The interdigital capacitor consists of 10 fingers with length $L_f = 18\text{mm}$; width of each finger and the gap between fingers is the same $w = g = 1\text{mm}$. These same dimensions are used for all three applicators proposed in this work. The length of inductive parts (denoted in yellow) is $L_{\text{ind}} = 50\text{mm}$. The interdigital capacitor is connected to the ground plane by the so called air-bridges. Thanks to the zeroth-order mode, currents flowing through the air bridges are approximately the same amplitude and phase and contribute significantly to the overall radiation. Here the shielded version of the antenna is presented which eliminates radiation to the back side. Unshielded versions

can be designed as well with almost the same overall dimensions.

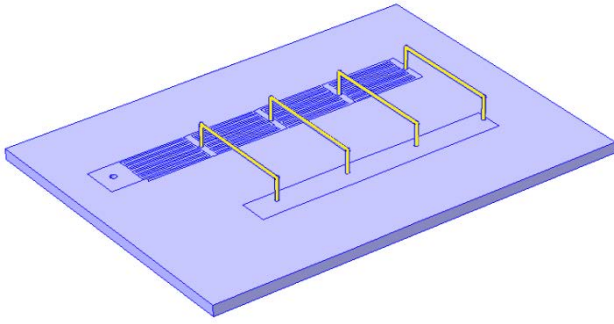

Fig. 1. Aperture view of Applicator 1. The inductive parts between the interdigital capacitor and ground plane (highlighted in yellow) are created by air bridges with a height of 1.0cm. Overall dimensions of the structure are 150x68x16 mm.

The second proposed applicator (Applicator 2) (shown in Fig. 2) is based on microstrip technology which allows very thin and low profile applicator construction. The input impedance of this structure at the operating frequency is about 5 ohms [4]. To improve applicator reflection coefficient, a $\lambda/4$ impedance transformer is used. The length of the impedance transformer is 107 mm. The impedance transformer increases the applicator overall dimensions from 80 mm (without the impedance transformer) to 187 mm (the impedance transformer included). The longitudinal dimension of the applicator can be decreased by using a double layered dielectric substrate with the impedance transformer on the other side. The inductive microstrips are grounded by capacitors. The interdigital capacitor for this design consists of four fingers. The length of each finger is $L_f = 18$ mm, length of the inductive part is $L_{ind} = 41$ mm, length of the unit cell $L = 22$ mm, and dimensions of grounded capacitor are 16×13 mm².

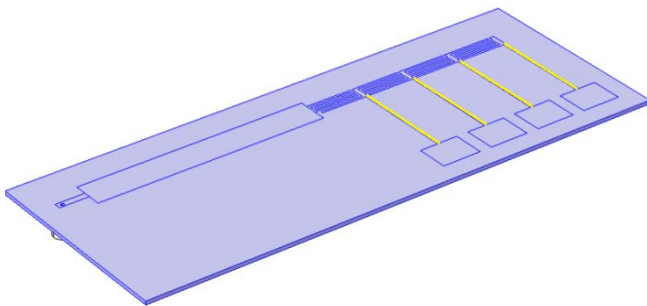

Fig. 2. Aperture view of Applicator 2 based on microstrip technology. Antenna dimensions are 187x56mm for a substrate thickness of 1.5mm

The third proposed applicator (Applicator 3) (see Fig. 3) is also based on microstrip technology, but the substrate is composed of two layers of FR4 and air of height $h_{air} = 7$ cm. In this design, the elements which radiate dominantly are the vertical parts (highlighted in yellow). Together with the 5 elements, electric currents in the feeding pins have equal phase. This type of antenna is fed in the middle to produce symmetry in the induced power deposition.

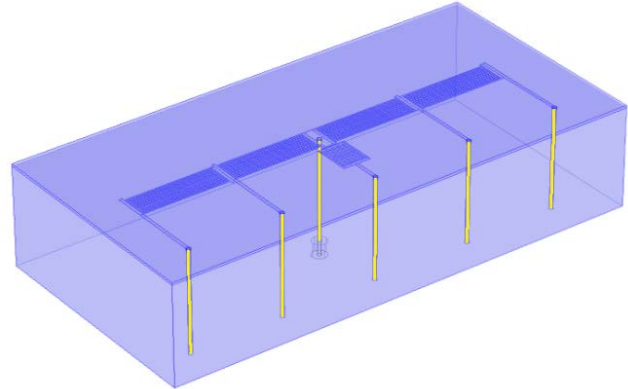

Fig.3. Applicator 3 based on microstrip multi-layer dielectric/air substrate technology. Antenna dimensions are 277x98x70mm [1]

III. RESULTS

Figs. 4-6 show power deposition distributions induced in numerical muscle tissue-equivalent phantom models 1cm under the tissue surface. Plotted contours circumscribe the region of 75, 50 25 percent of power absorbed in the tissue.

In numerical models, all three antennas radiate into the muscle tissue through a layer of deionized water of 1 cm thickness. The water layer represents the so called water bolus, which during hyperthermia treatment cools down surface of the treated biological tissue. The water bolus is not necessary for the impedance matching or for miniaturization of applicator dimensions. Dielectric properties of materials considered in numerical models are listed in Tab. 1.

It can be observed that when the EM power penetrates the biological tissue, it has very good power deposition homogeneity and that the penetration depth is approaching the theoretical limit for plane wave radiation.

The power deposition for applicators proposed here is depicted in Figs. 4-6. The power deposition symmetry and homogeneity depends on the current distribution on the applicator structures. The current distributions in applicator apertures is symmetric for Applicator 3 only. Therefore the power deposition is symmetric for Applicator 3 only as well. In Applicators 1 and 2 the power deposition symmetry is influenced by both a nonsymmetric location of feeding point and spatial orientation of the applicators' layout. In the case of Applicator 2 the power deposition inhomogeneity is

caused by the bigger current density on the last interdigital capacitor.

Table I
DIELECTRIC PROPERTIES OF MATERIALS USED IN NUMERICAL MODELS AT 434 MHz

Material	ϵ_r [-]	σ_e [S/m]
Dielectric Substrate FR4	4.3	0
Deionized water	80	5.5e-6
Muscle tissue	57	0.81

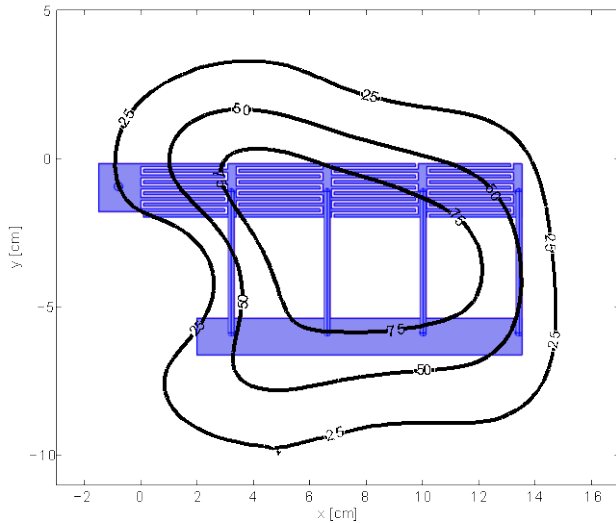

Fig. 4. Power deposition distribution from Applicator 1 prototype based on micro-coplanar technology.

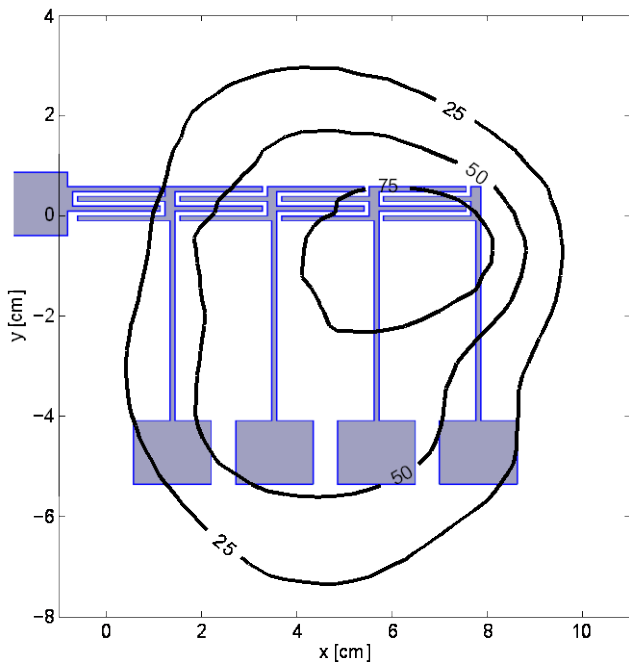

Fig. 5. Power deposition distribution from Applicator 2 prototype.

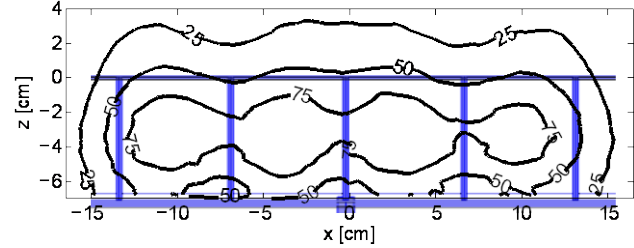

Fig. 6. Power deposition distribution from Applicator 3 prototype.

IV. CONCLUSIONS

In this paper, a novel principle for the design of applicators based on MTM structures is proposed. Results demonstrate that when penetrating biological tissue, EM waves generated by the proposed applicators generate very good power deposition distribution. According to the results from previous chapter we can state that the key to symmetric and homogeneous power deposition lies in feeding the structures centrally and design the applicators symmetric as in the case of Applicator 3.

ACKNOWLEDGEMENT

This research has been supported by the research program of the Grant Agency of the Czech Republic, Project no. 13-29857P Human Body Interactions with EM Field Radiated by Metamaterial Structures and Project no. 14-00386P Study of Thermal and Nonthermal Effects of High-Power EM Field Structure of Matter.

REFERENCES

- [1] D. Vrba, J. Vrba, „Novel Applicators for Local Microwave Hyperthermia Based on Zeroth-Order Mode Resonator Metamaterial”, *International Journal of Antennas and Propagation*, vol. 2014, April, 2014
- [2] Y. Tao a G. Wang, „Conformal hyperthermia of superficial tumor with left-handed metamaterial lens applicator”, *IEEE Trans Biomed Eng.*, . vol.59, issue. 12, pp. 3525–3530, Dec. 2012.
- [3] M. Polívka and D. Vrba, „Shielded micro-coplanar CRLH TL zeroth-order resonator antenna: Critical performance evaluation. *Radioengineering*, 18(1):368_372, 2009.
- [4] A. Sanada, M. Kimura, I. Awai, C. Caloz, a T. Itoh, „A planar zeroth-order resonator antenna using a left-handed transmission line”, in *Microwave Conference, 2004. 34th European*, 2004, vol. 3, pp. 1341–1344.
- [5] M. Polívka and D. Vrba, „Input resistance of electrically short not-too-closely spaced multielement monopoles with uniform current distribution. *IEEE Antennas and Wireless Propagation Letters*, vol. 11, no. 1:1592_1595, 2012.