

5-1-2018

Guardlock

Michael Grosso
Thomas Jefferson University

Joe Mooney
Thomas Jefferson University

Follow this and additional works at: <https://jdc.jefferson.edu/idcapstones>



Part of the [Industrial and Product Design Commons](#)

[Let us know how access to this document benefits you](#)

Recommended Citation

Grosso, Michael and Mooney, Joe, "Guardlock" (2018). *Program of Industrial Design Capstones*. Paper 17.
<https://jdc.jefferson.edu/idcapstones/17>

This Article is brought to you for free and open access by the Jefferson Digital Commons. The Jefferson Digital Commons is a service of Thomas Jefferson University's [Center for Teaching and Learning \(CTL\)](#). The Commons is a showcase for Jefferson books and journals, peer-reviewed scholarly publications, unique historical collections from the University archives, and teaching tools. The Jefferson Digital Commons allows researchers and interested readers anywhere in the world to learn about and keep up to date with Jefferson scholarship. This article has been accepted for inclusion in Program of Industrial Design Capstones by an authorized administrator of the Jefferson Digital Commons. For more information, please contact: JeffersonDigitalCommons@jefferson.edu.

Table Of Contents

Mission Statement

01-Research

Problem

Demographic

Market Analysis

Market Opportunity

02- The Process

Early Development

Round One Testing

Sketch Development

Round Two Testing

Detailed Development

03-Final Design

Final Renderings

How It Works

Materials/Manufacturing

User Interaction

04-Final Model

Mission Statement

An analog pistol lock that stays attached to the pistol at all times, for in-home defense and unwanted user firearm discharge.



01

Research

The Problem

"In 2014, 2,549 children (age 0 to 19 years) died by gunshot and an additional 13,576 were injured." - CHOP

"More than 75 percent of first and second graders know where their parents keep their firearms and 36 percent admitted handling the weapons, contradicting their parents' reports." - CHOP

"Among children, the majority (89%) of unintentional shooting deaths occur in the home. Most of these deaths occur when children are playing with a loaded gun in their parent's absence." - CHOP

"Approximately one of three handguns are kept loaded and unlocked and most children know where their parents keep their guns." - CHOP

*"A study showed that about **1.4 million** households (with an estimated **2.6 million** children) had firearms stored unlocked and either loaded or with ammunition nearby. - RAND corporation*

Gun Accident Statistics

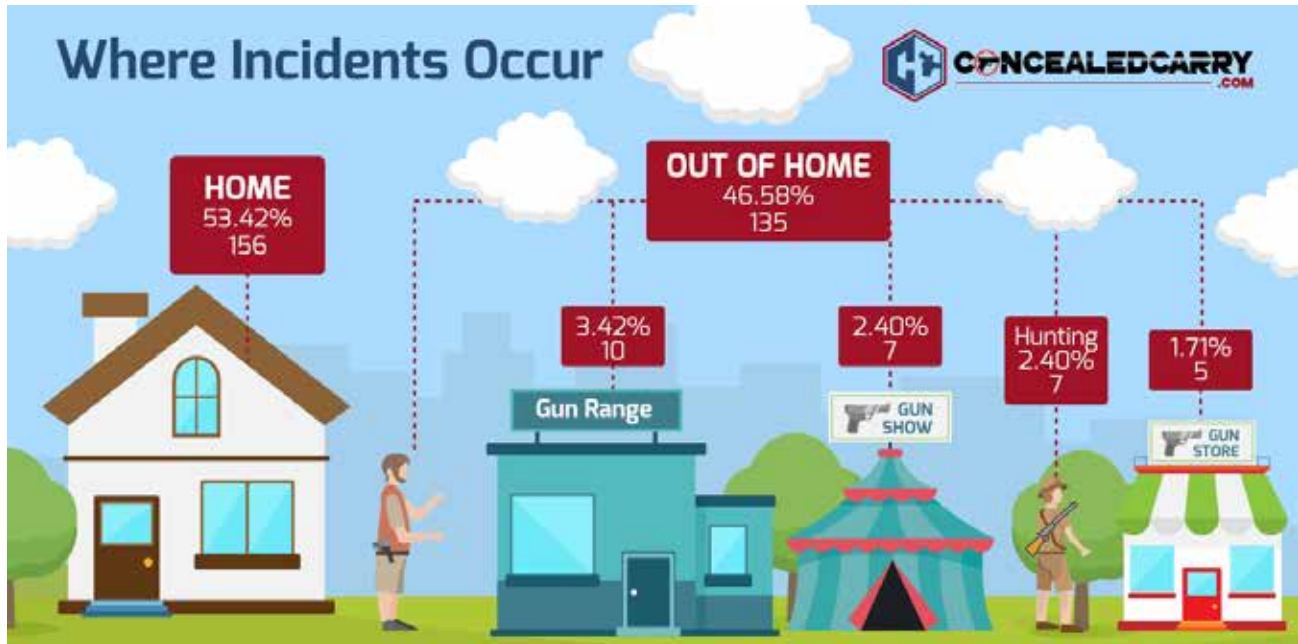

GUN TYPE

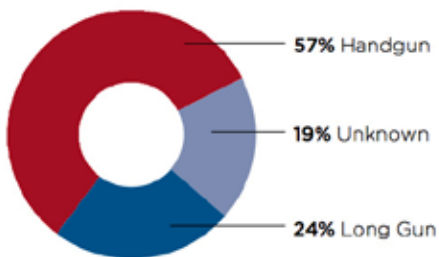

WOULD RESPONSIBLE STORAGE HAVE PREVENTED THE DEATH?

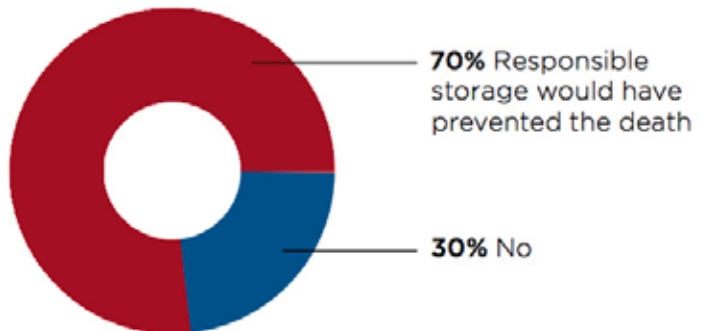

SHOOTER AGE

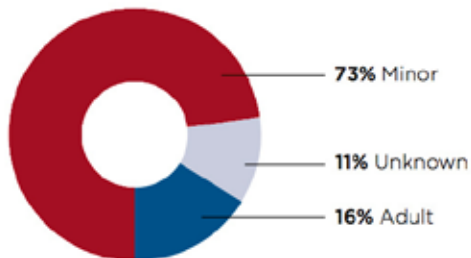

Problem Statement

As a firearm owner, it is your responsibility to ensure that guns in your home are always stored where they are inaccessible to children or other unauthorized persons. **Hiding a gun in a closet, drawer or similar location is not a safe option.**

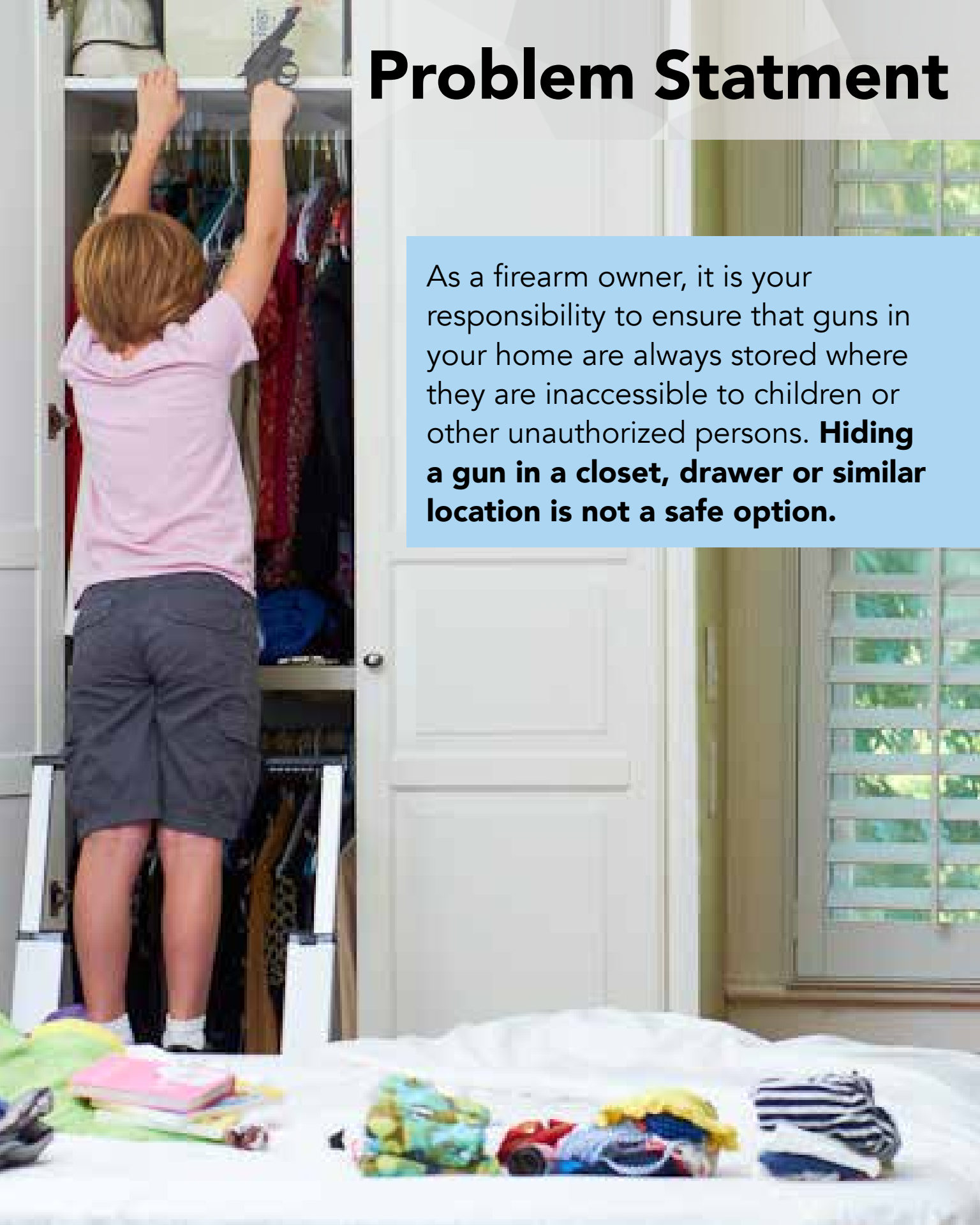

Demographic

Our target demographic includes anyone that owns a pistol.



More specifically, we are focusing on the average homeowner that owns a pistol to protect their home and family, but do not properly store them.



Based on our research of accidents with firearms, its clear that it initially begins with the everyday home owner and how and where they keep their firearms inside their homes.

**Children live with
unlocked
firearms**

1.7M

Million Children live in a home
with an unlocked Loaded Gun

**Children know
where firearms
are**

76%

Of children ages 5-14 know where
firearms are kept in the home

**It happens in the
home**

87%

Of firearm deaths of children under
10 take place in a home

**Firearm
Suicides**

82%

Of firearm suicides among youth under 18 used a firearms
belonging to a family member, usually a parent

Focusing on home owners and how they store there handguns within their dwelling, will be the most effective way to help prevent accident related gun violence, by creating a safe system that stays attached to the firearm.

Current Storage Methods



Concealed and accessible

Pros:

- concealed
- easy Accessibility
- convenient for users intended atmosphere

Cons:

- no code nor lock for intended users
- accessibility to unintended users
- easy to accidently find



Out in the open or unprotected

Pros:

- easy accessibility

Cons:

- Accessible by all users
- no code nor lock for intended users
- not concealed
- easy to accidently find

Current Storage Methods



In a Safe

Pros:

- ability to fit multiple firearms
- hard to access by force
- code for intended users

Cons:

- takes a long time to access firearm
- no mobility
- not space friendly
- clutter of multiple firearms



In Drawer, Desk or a Cabinet

Pros:

- easy accessibility
- multiple drawers in home to choose from
- concealed

Cons:

- accessibility of unwanted users
- no code nor lock for intended users
- cluttered drawer and uncovered trigger is unsafe
- unprotected when mobile with firearm

Market Analysis

\$13.5 billion annual revenue of gun and ammunition manufacturing industry, with a **\$1.5 billion** profit.

A SURGE IN HANDGUN OWNERSHIP

Of the approximately 70 million guns added to the civilian arsenal since 1994, roughly 46 million were handguns.

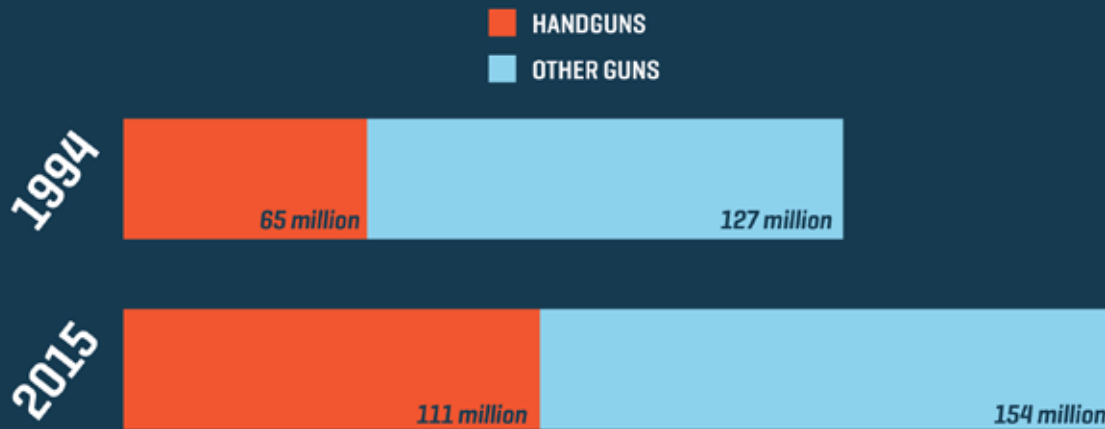

SOURCES: National Institute of Justice, Harvard Injury Control Research Center, Northeastern University



\$42.9 billion Estimated overall economic impact of the firearms and ammo industry in the U.S.



IdentiLock

Price: \$239

Company: Identilock

Dimensions: 4"x5"x1.5" inches

OL/IS: Online only

Features: 360° Fingerprint Recognition;
Rechargeable Li-Ion; Type-C USB Charging Port;
LED Indicators Key Lock Cover



IC lock for handguns

Price: \$35

Company: IC13

Materials: aircraft grade aluminum

OL/IS: online and in stores

Features:

Mount on any wall or on our Mount Up! rail system, Easy to install, Made from aircraft grade aluminum,



ZORE

Price: \$175

Company: ZORE

Dimensions: 11.6" x 10" x 2.7"

Materials: Aluminum

OL/IS: Online only

Features: electro-mechanical lock; caliber specific and will fit almost any firearm of a specific caliber; turn the dial a few notches back and forth according to your PIN code;



Gunbox 2.0

Price: \$259

Company: Gunbox

Model: 2.0

Dimensions: 11.6" x 10" x 2.7"

Materials: 4mm Die Cast Aluminum

OL/IS: Online only

Features: Biometric Unlock, RFID Unlock, Bluetooth Unlock, Hydraulic Opening, USB Charge Ports, Audible Motion Alarm, Pre Drilled Mounting Holes, Secures With Tether Cable (sold separately), Interior LED



Gun trigger lock 3 combination GL-20

Price: \$22.99

Company: 321 locks

Model: GL-20

Dimensions: 6.5 x 2.8 x 1.8 inches

Materials:

OL/IS: in stores and online

SKU:

Features: 3 Pack Combination, No Keys to Carry for Fast Access

Rubber proctor to protect your gun from scratching.

Ultimate Safety and Security for you Guns - Keeping your family safe Fits Most Hand Guns, Fillies and Shotguns



Stack-On Portable Security Case With Key

Price: \$19.99

Company: Stack-On

Model: PC-95K

Dimensions: 1.75"H x 9.5"W x 6.5"D

Materials: steel cable, Foam-padded interior

OL/IS: in stores on line

SKU: 13536002

Features: Portable safe with key-coded locking system

Slim design for storage in briefcase, under car seat or in luggage

Foam-padded interior for maximum protection

Meets TSA airline firearm guidelines

Market Opportunity

Here we utilized a table to organized a few of the products into high vs low price and electronic vs non electronic categories to identify where we fit within the market. After researching the market it was clear that our opportunity fits in the non electronic area with a mid price range to suit the reliability and efficiency that consumers are looking for.

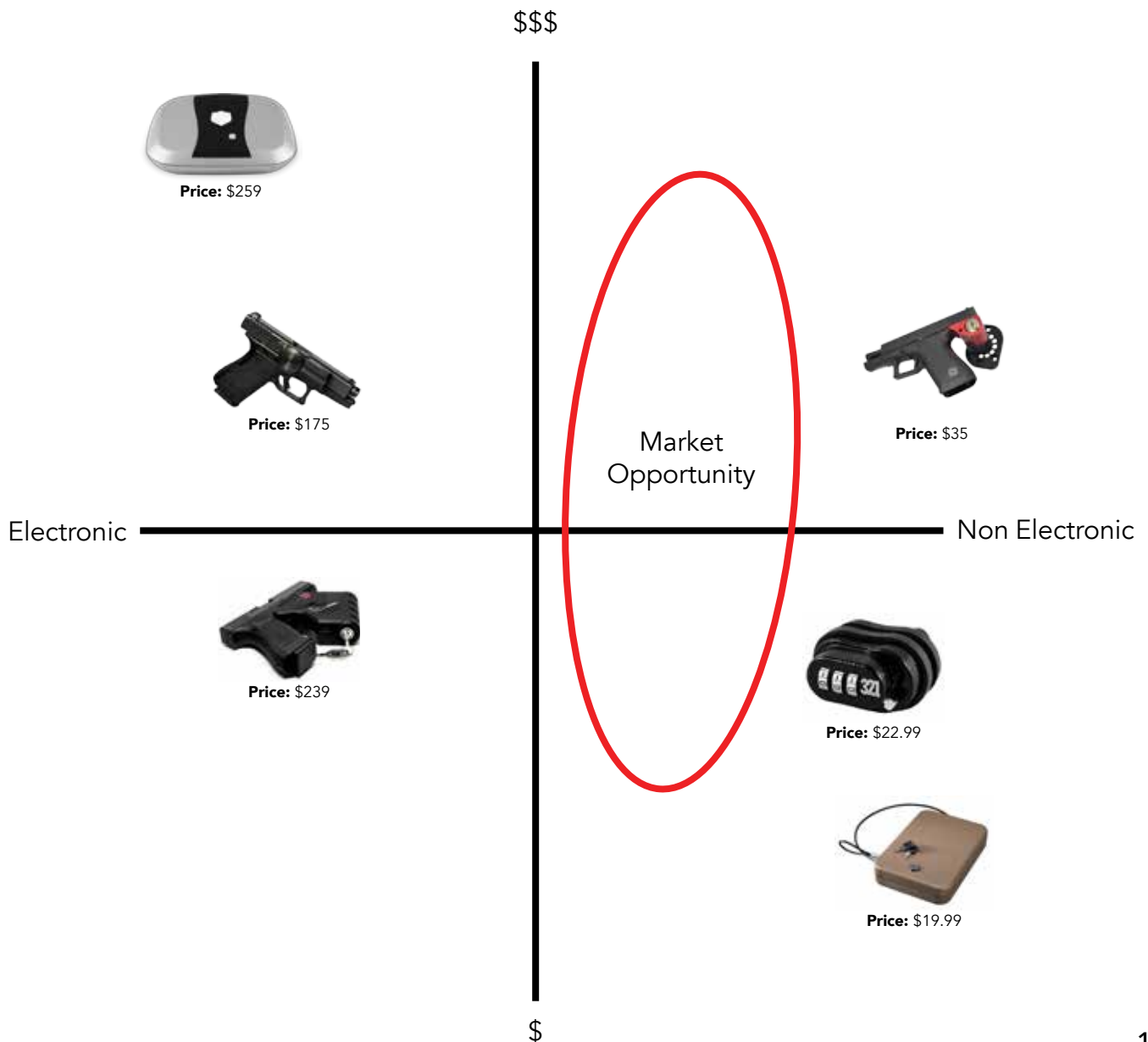



02

The Process

Early Development



In the beginning stage of development we knew we wanted our device to attach on the front of the firearm

Utilizing a front picatinny rail attachment, made our device universal to all pistols that have picatinny rail





Although we knew we wanted our device to be located and attached, we had to assess the orientation of the tab and how it would move away from the trigger guard







After testing several prototypes we found that after the code was entered the tab springing forward was mor convenient than the tabs swinging down due to the tabs obstructed by the users hand.

Round One Testing



In order to test out the existing tab lock mechanism for the guard lock, we built a semi functioning chassis around the existing lock mechanism

Our chassis was constructed using copper dowels and plates, solder, wooden shell, epoxy, and acrylic sliders

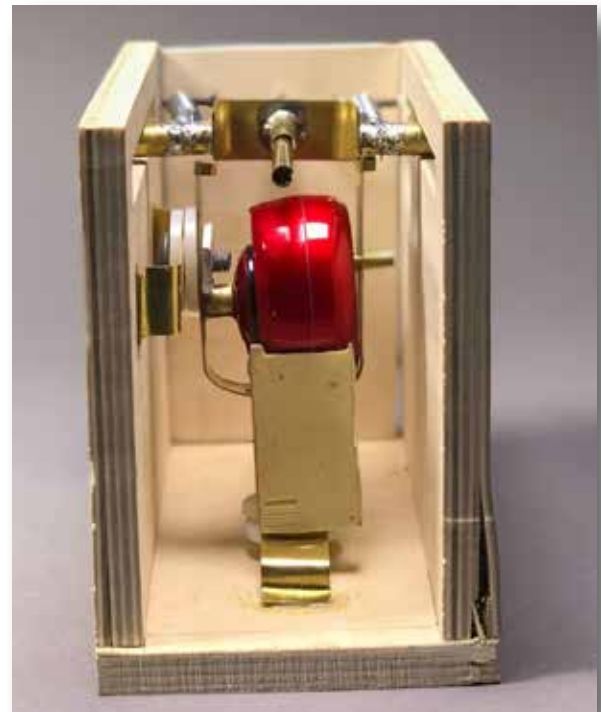

The intent was to utilize the up and down motion of the tab lock while positioned on its side to replicate how we wanted the lock system to be oriented.

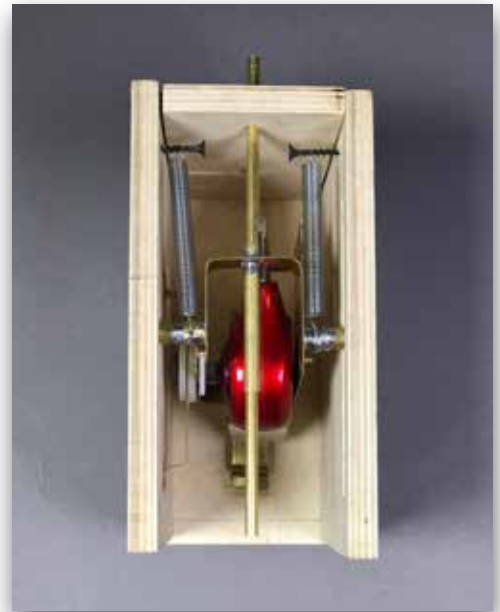

We connected the lock to a copper chassis attached to a horizontal track tensioned by a spring to replicate the tab shooting forward once the code was entered and it is released from the bottom chassis.

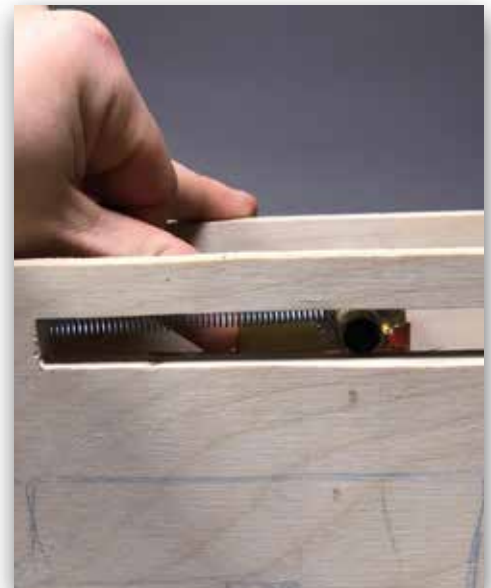
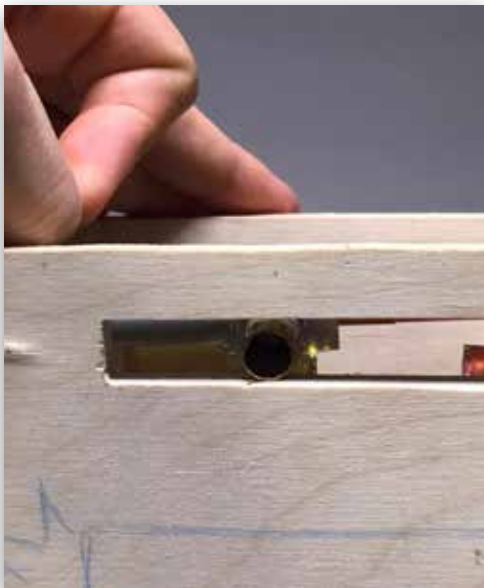





Closed



Here you will see the internals of the existing lock mechanism and highlighted in these images is the modified shackle block with the extension attached along with the unmodified version.

Open



Back

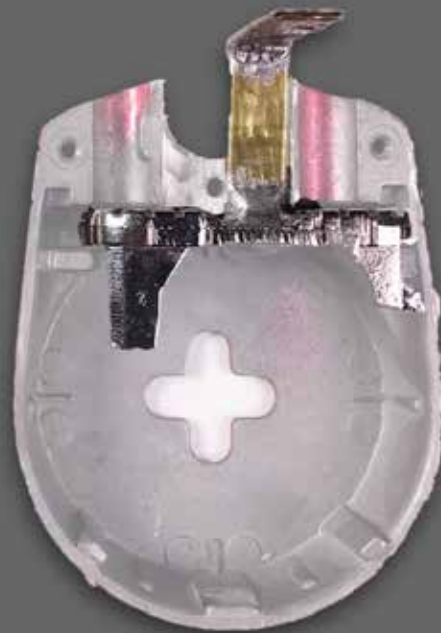

Front

The shackle extension is utilized to translate the shackle blocks motion when unlocked to the code chassis resulting in the release of the code and tab chassis.

Sketch Development

After our first round of testing it was time to focus on the aesthetics of our gun lock.

After looking at other picatinny gun accessories, we knew our product had to be rectilinear in shape while also visually reflecting gun aesthetics.

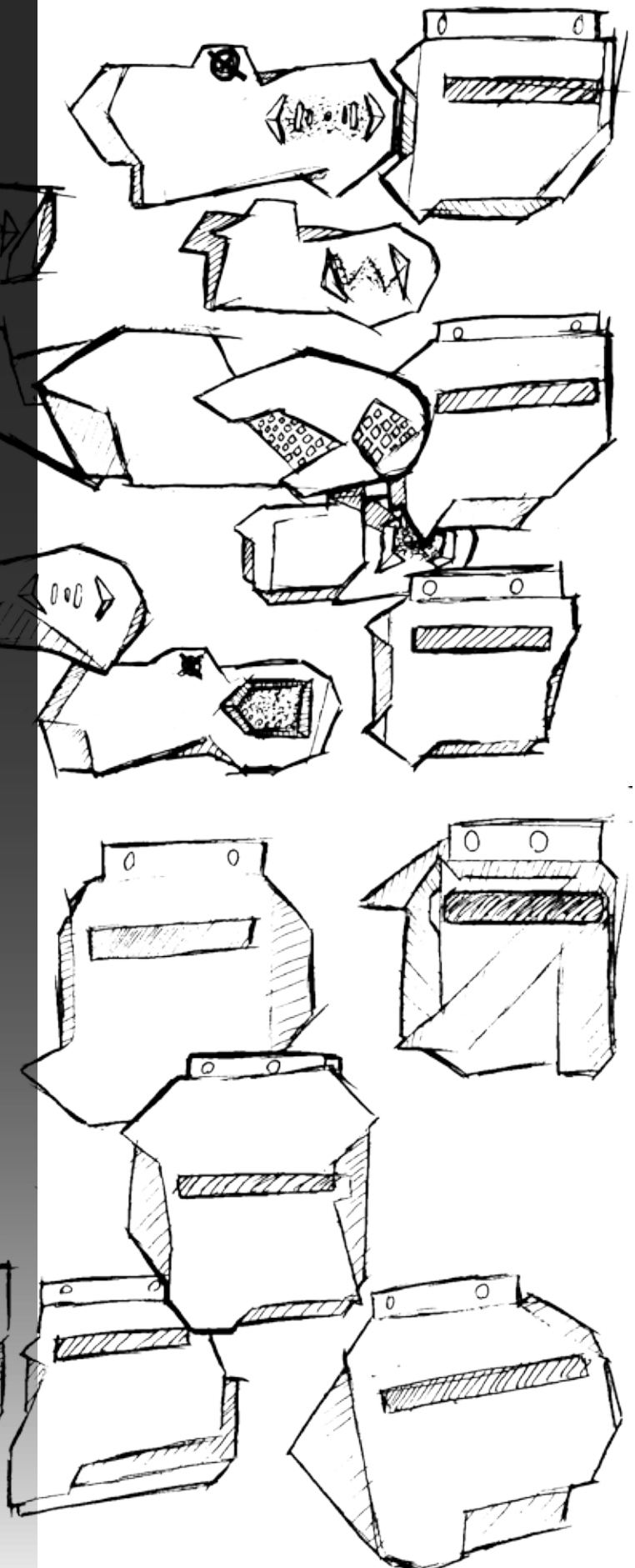
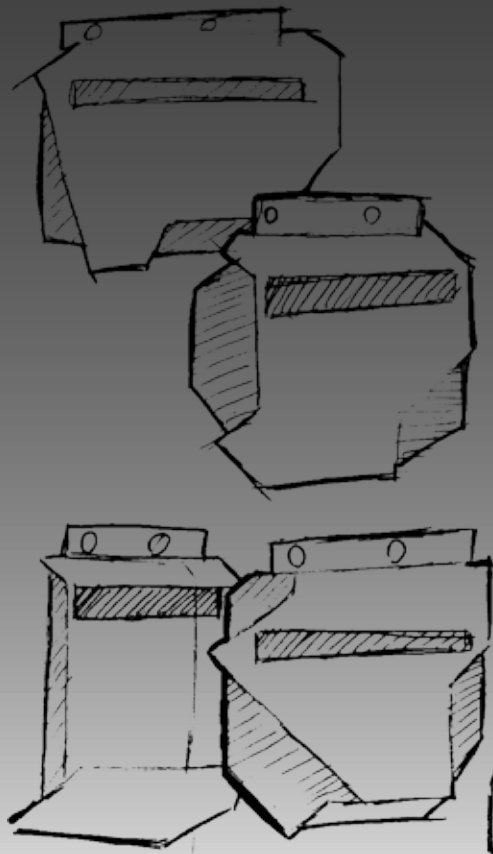

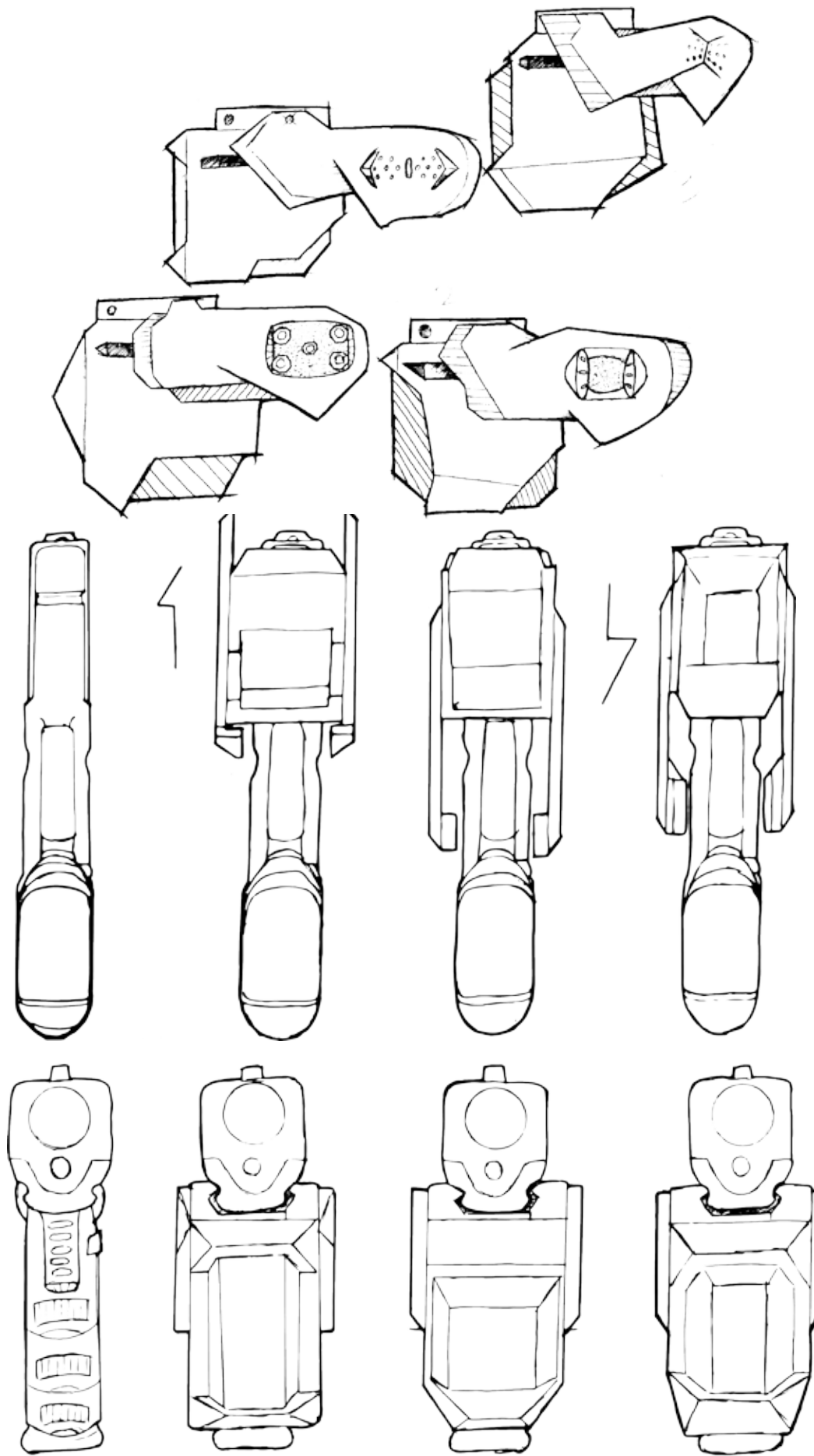

Round Two Testing

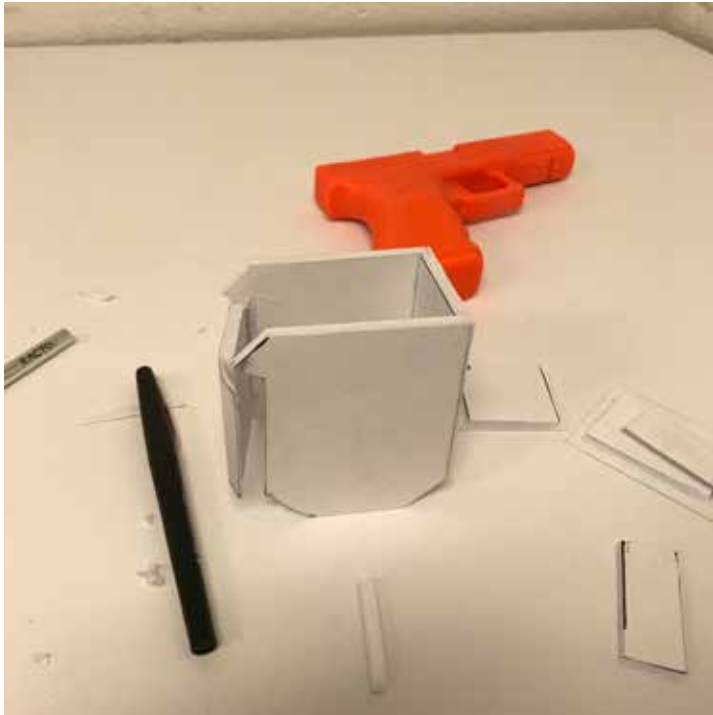

We began to focus more on the looks like models, considering the testing of the mechanics was a completely different mission.

The goal was to represent how much space the device will and could take up on the front of the firearm and overall translating previous sketches into what the lock should look like.



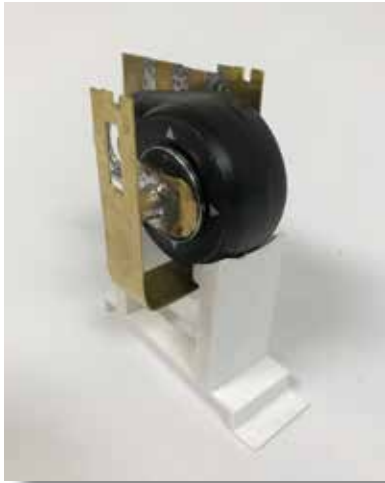

In this round of testing we wanted things to work a lot smoother than the original so we used 3D printed parts rather than separate pieces of brass and solder

In our previous models the lock mechanism did not work because we had a difficult time attaching a bent brass dowel to the shackle block to make contact with our chassis without having the internals flying all over the place. However we managed to cut a hole out of the top of the lock and the shackle block to firmly attach a brass dowel without destroying the internals. This allowed us to test with a functioning lock to interact with our chassis system.

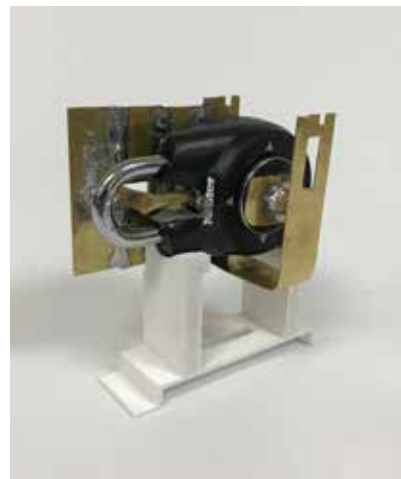



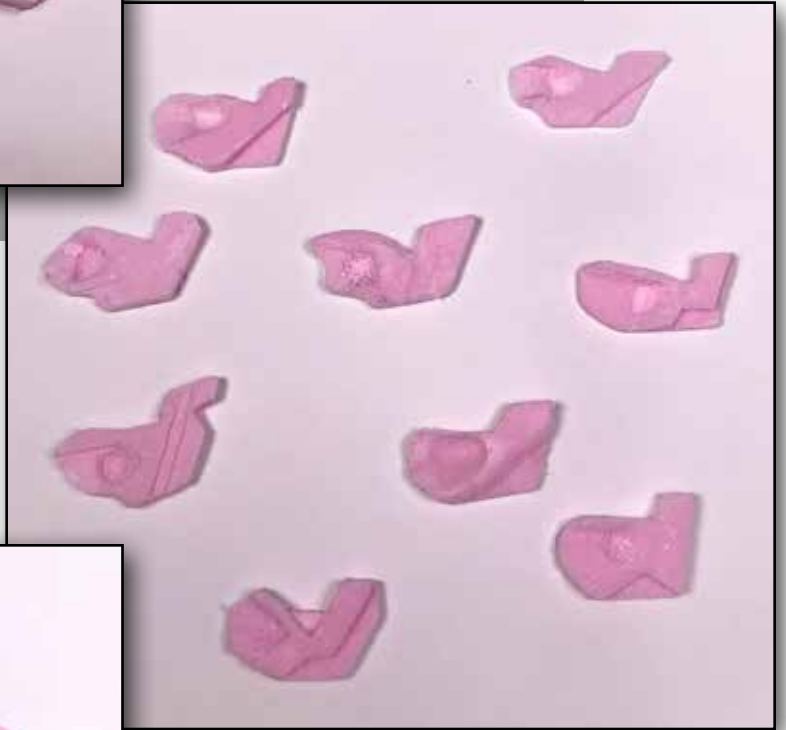

Detailed Development



After using the previous models for ergonomic studies, it was time to use a more suitable material for next Gen prototyping and applying features that worked on the previous studies .

The material was a 3d printed PLA plastic, so that we could achieve the accuracy of our CAD models.



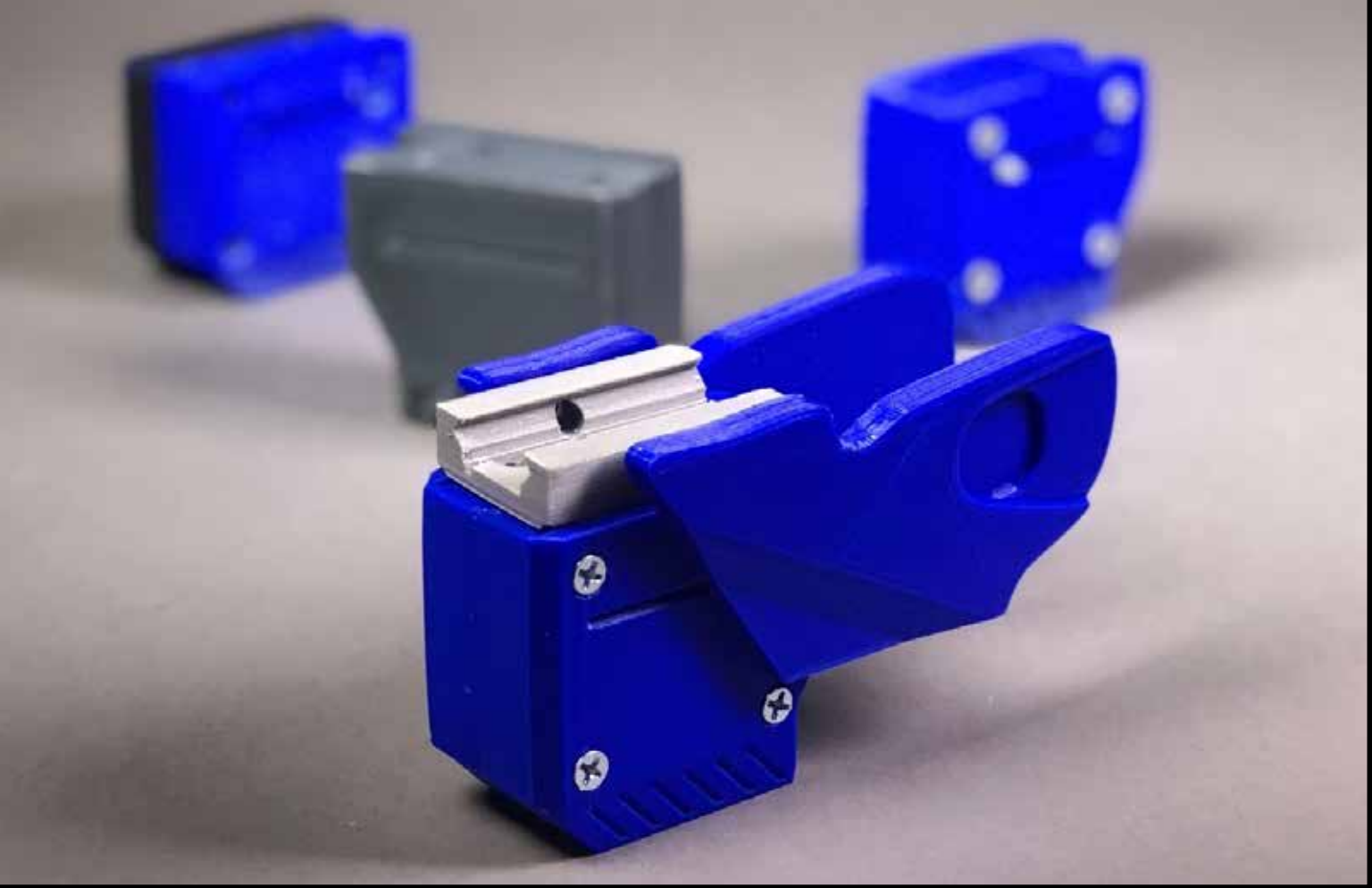





An abstract pattern of overlapping, irregular polygons in various shades of orange and peach, creating a textured, mosaic-like effect. The pattern is located on the left side of the page.

03

Final Design

Final Renderings



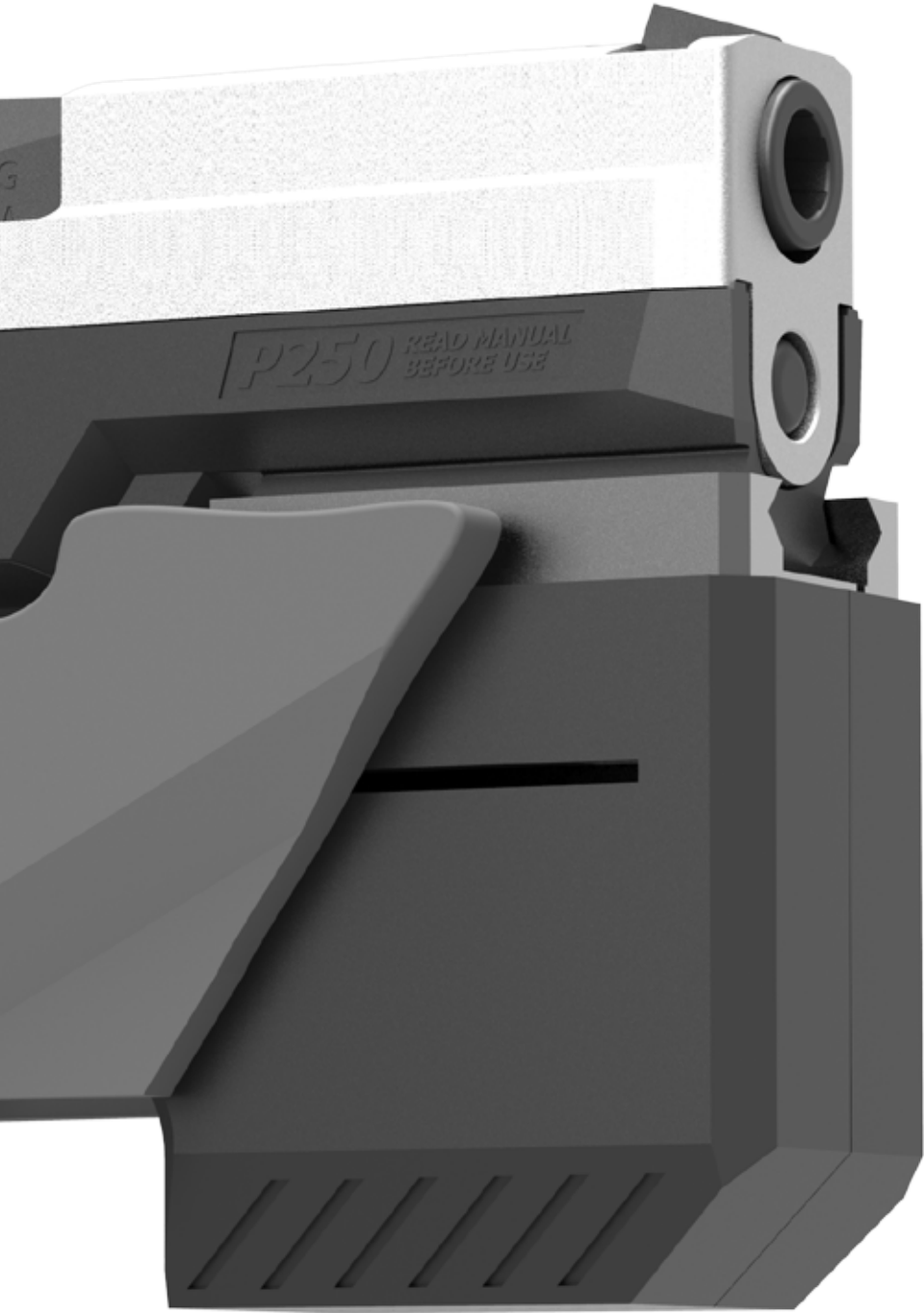



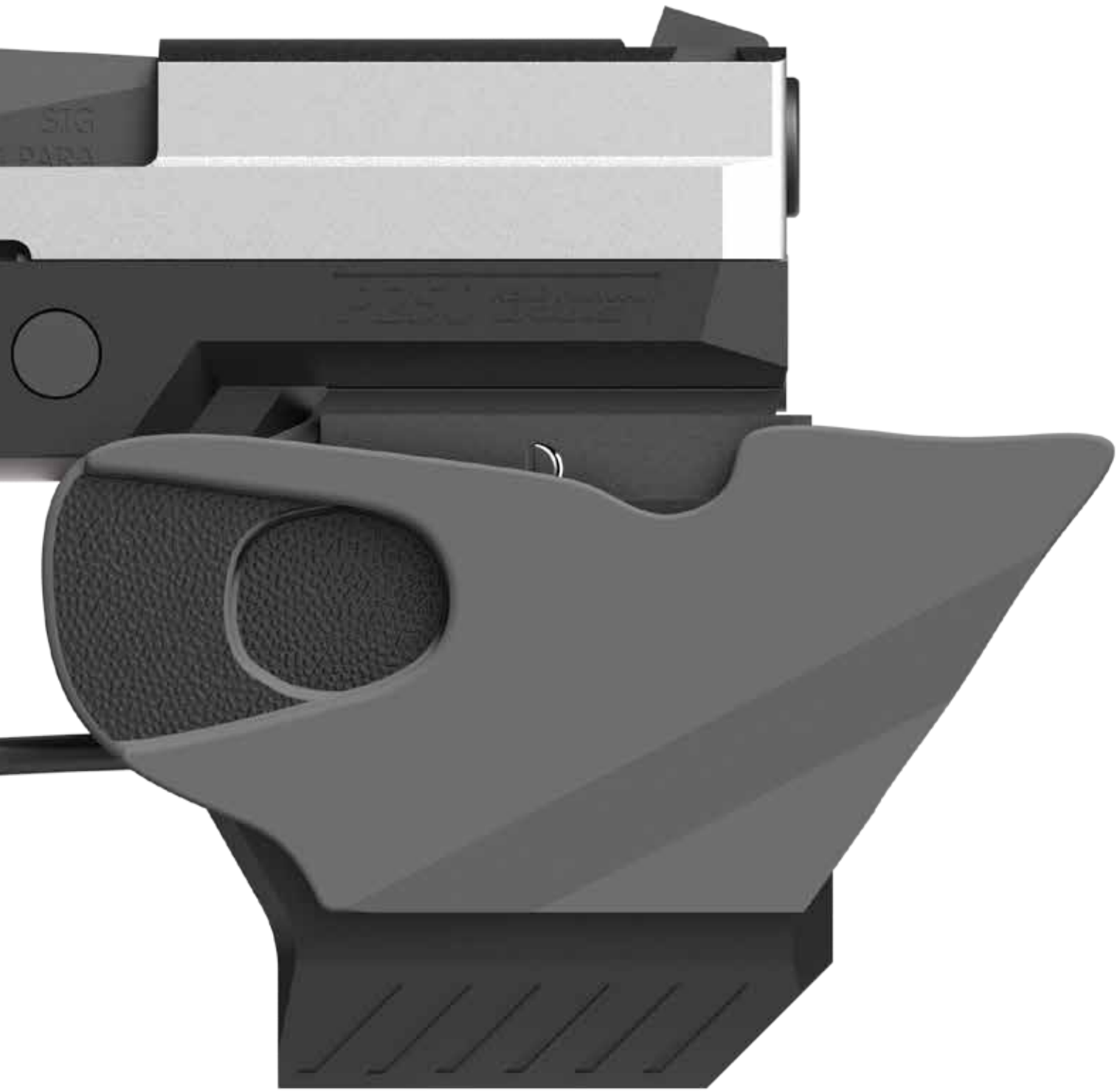

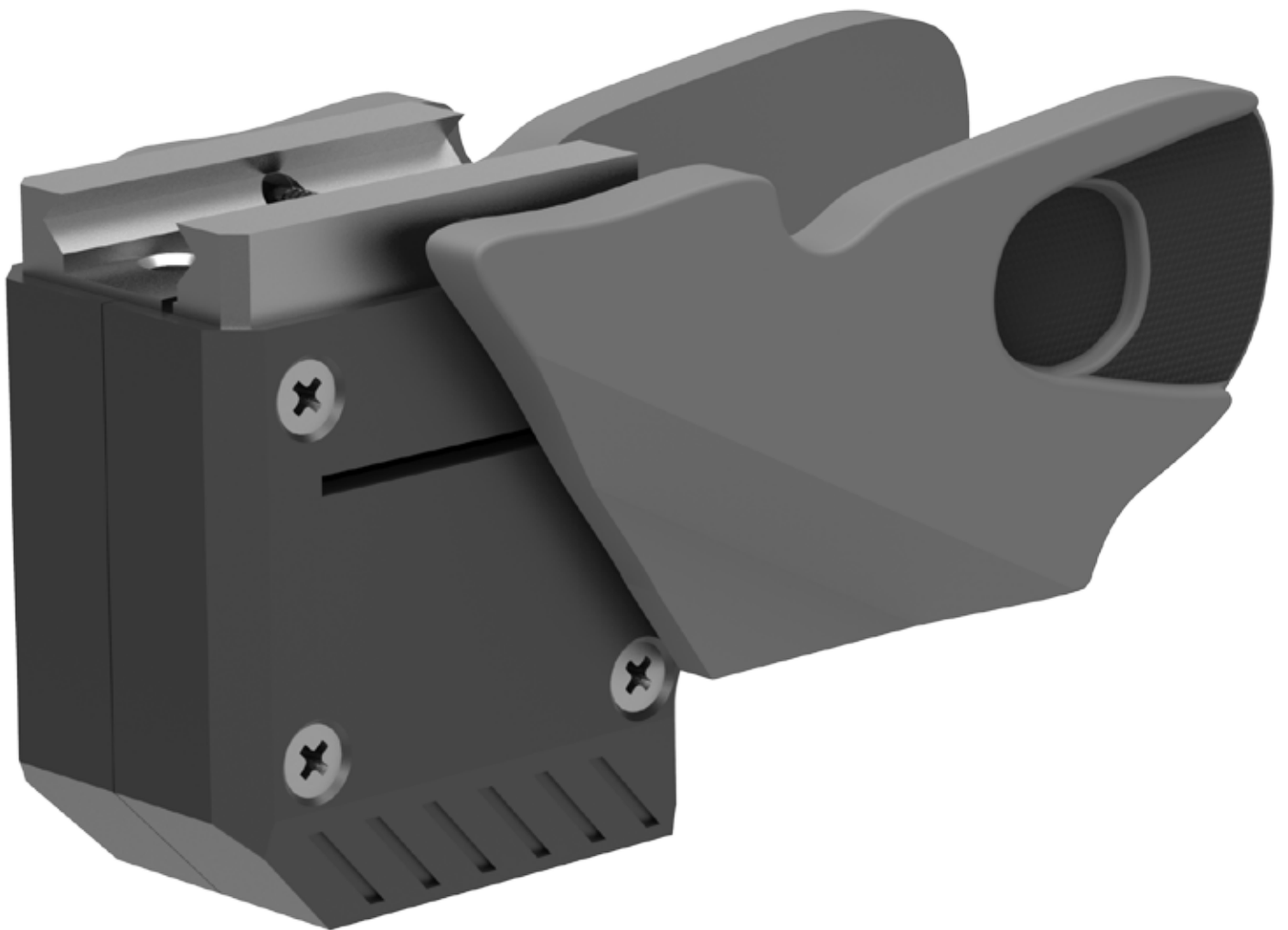







SIG

9MM PARA

P250 READ MANUAL BEFORE USE





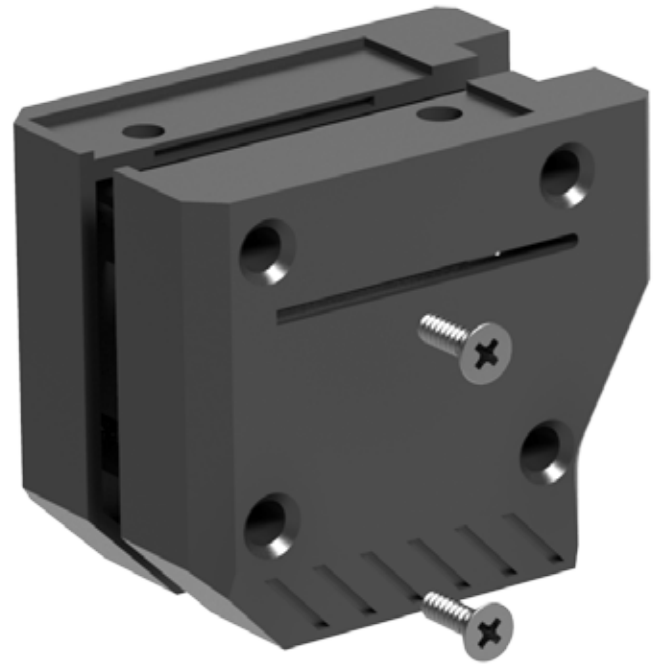
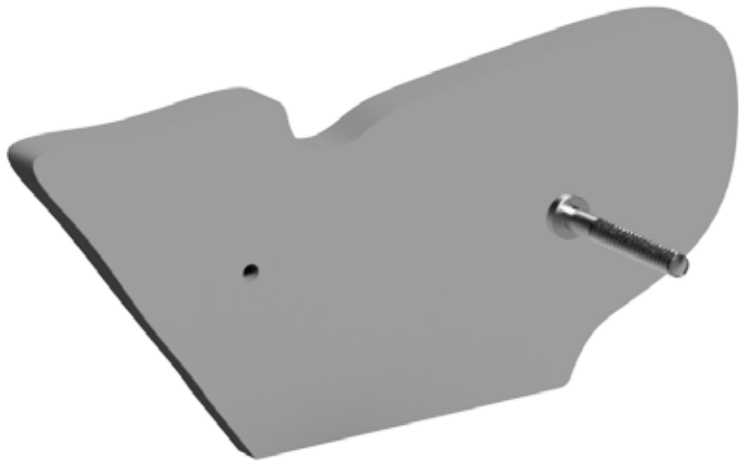

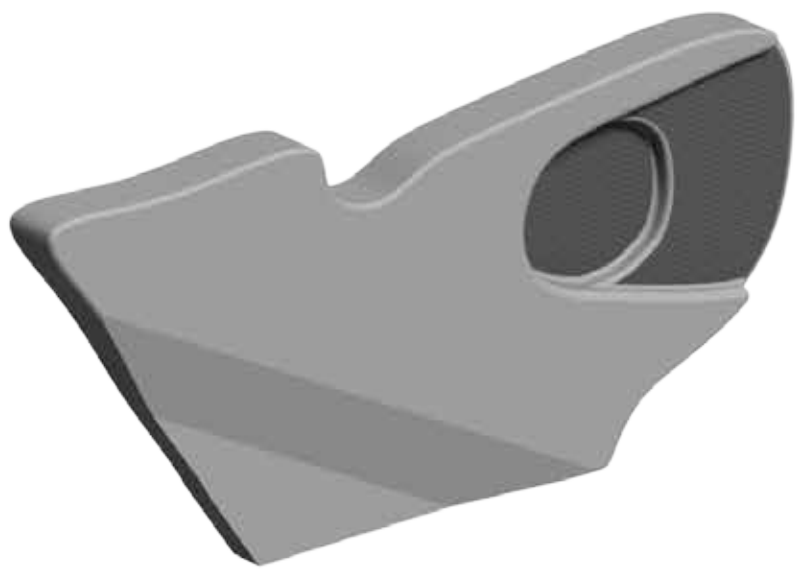

How It Works



Moving forward we created our works like model which utilizes the modified lock mechanism explained before. The structured consisted of clear acrylic walls so the internals could be visible, and it also allowed for labels to be applied to the walls for specific callouts.

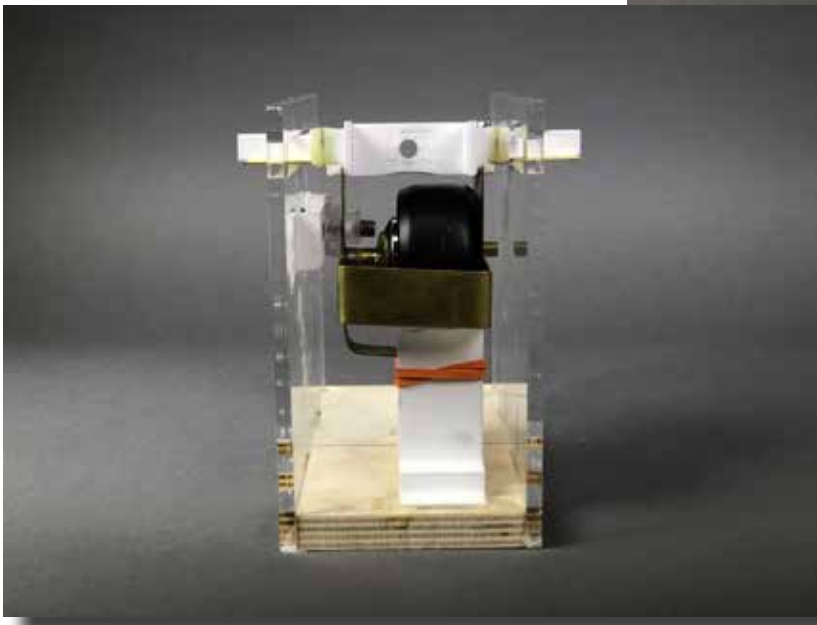
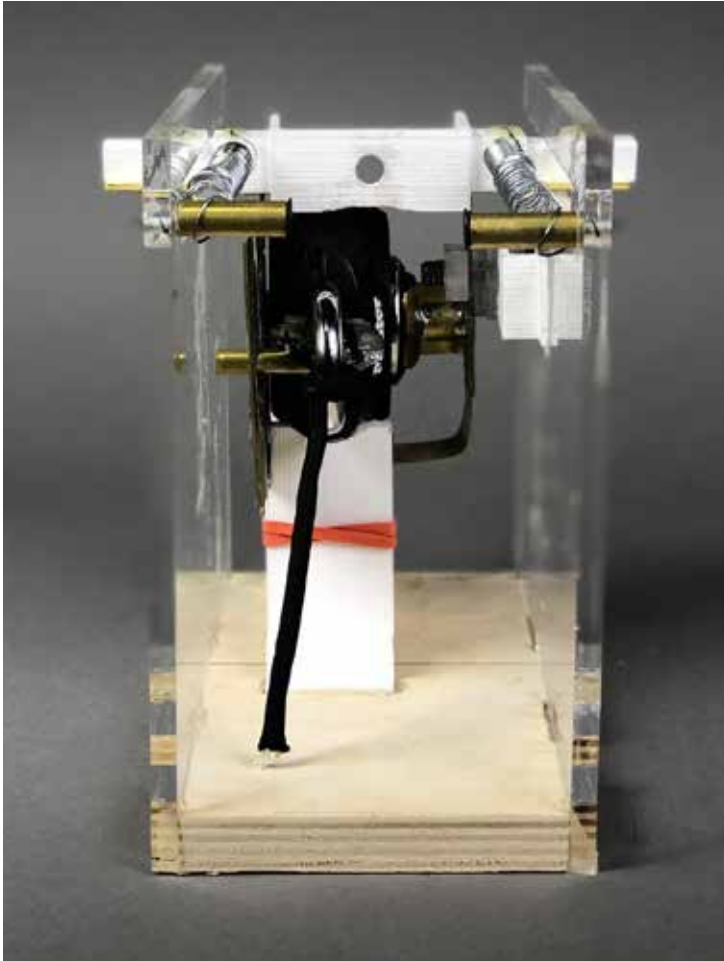

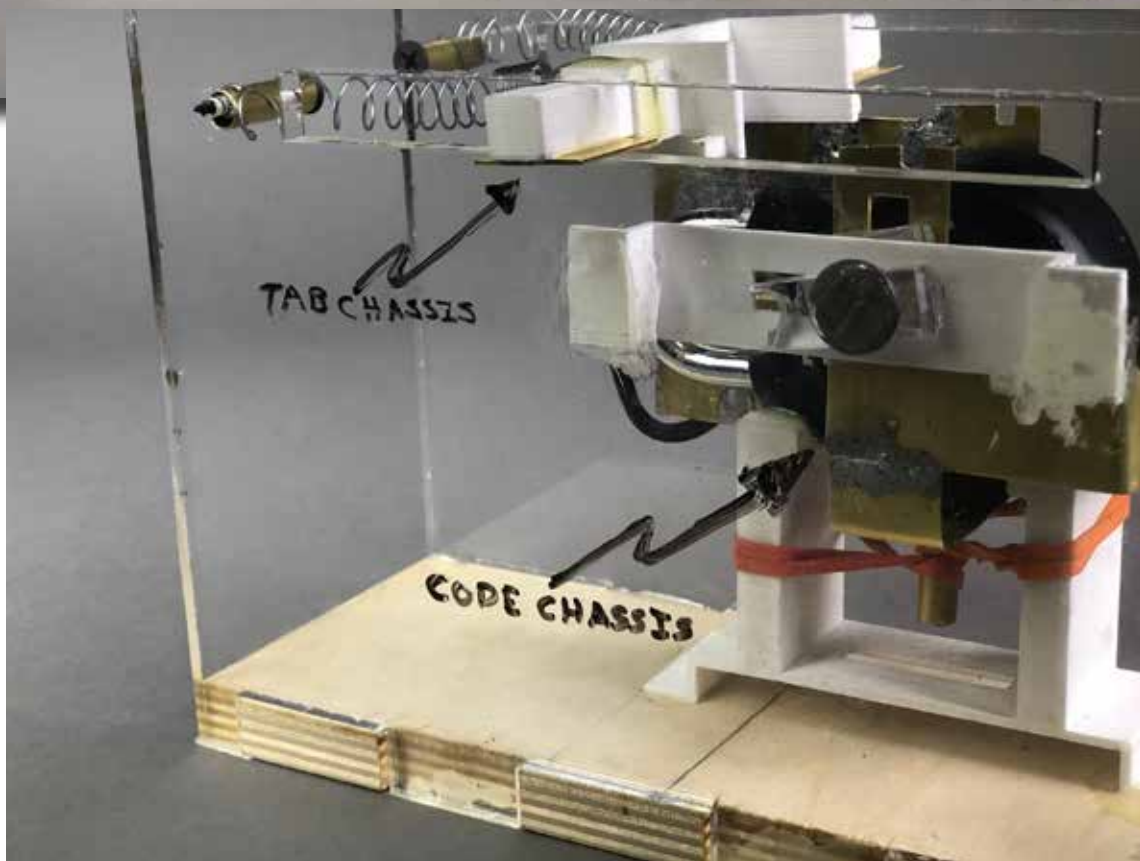
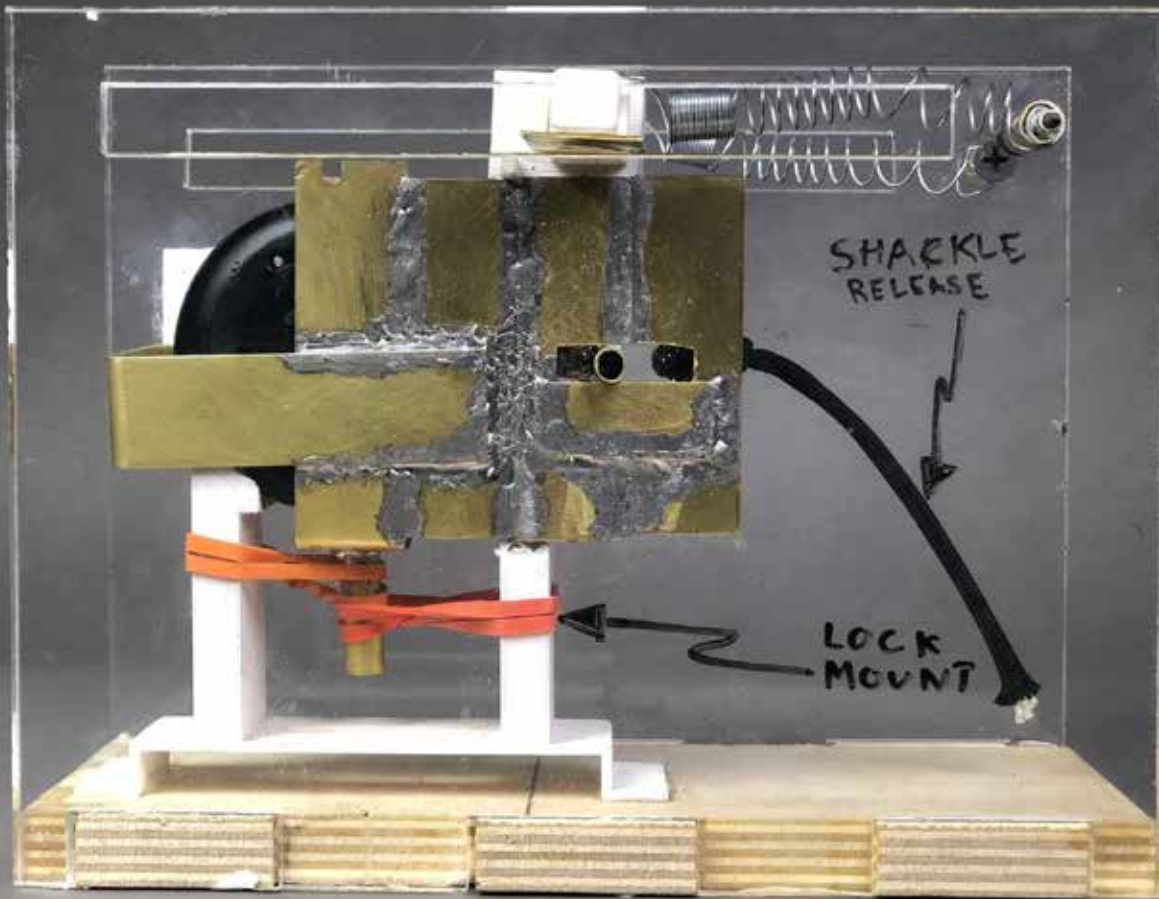

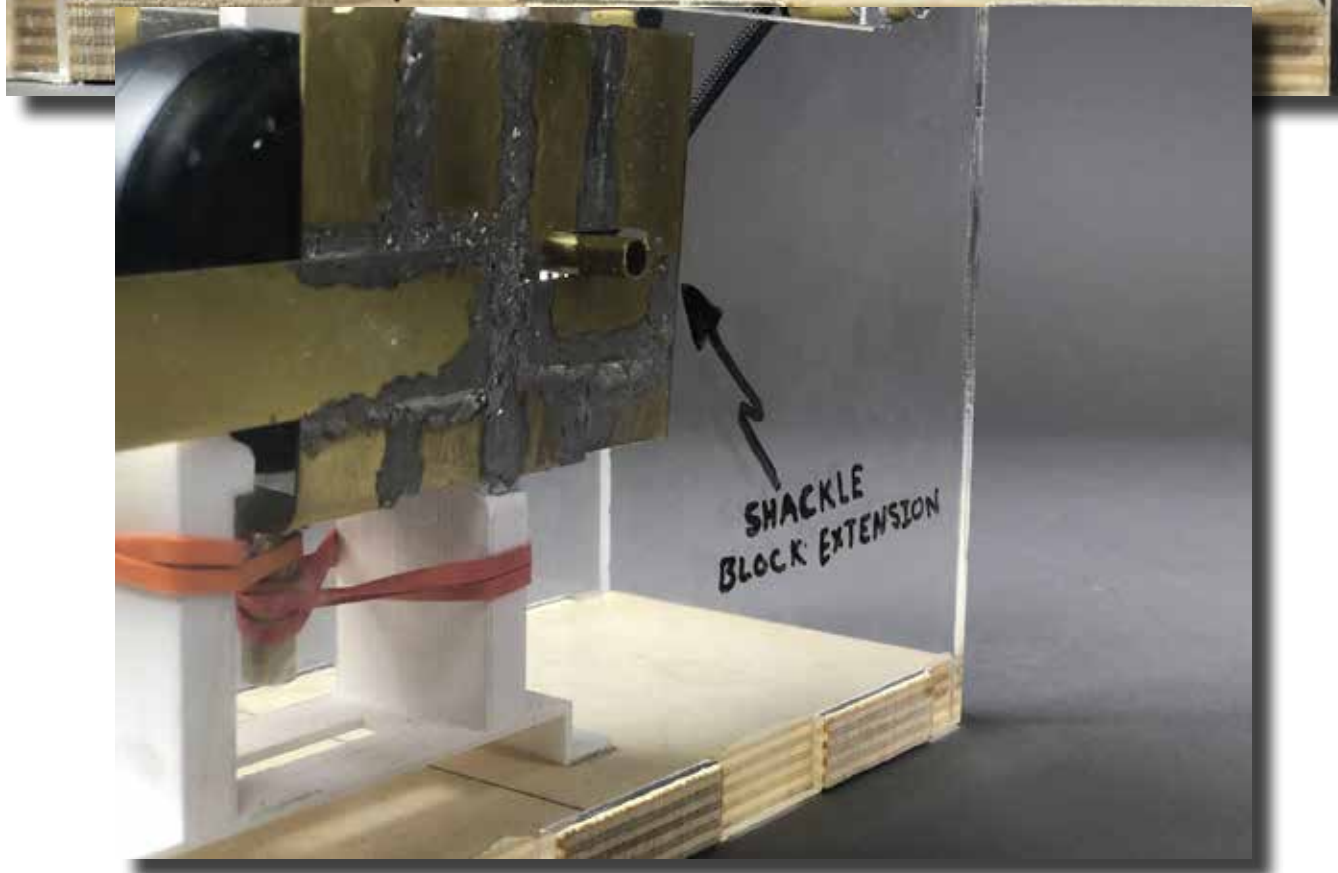
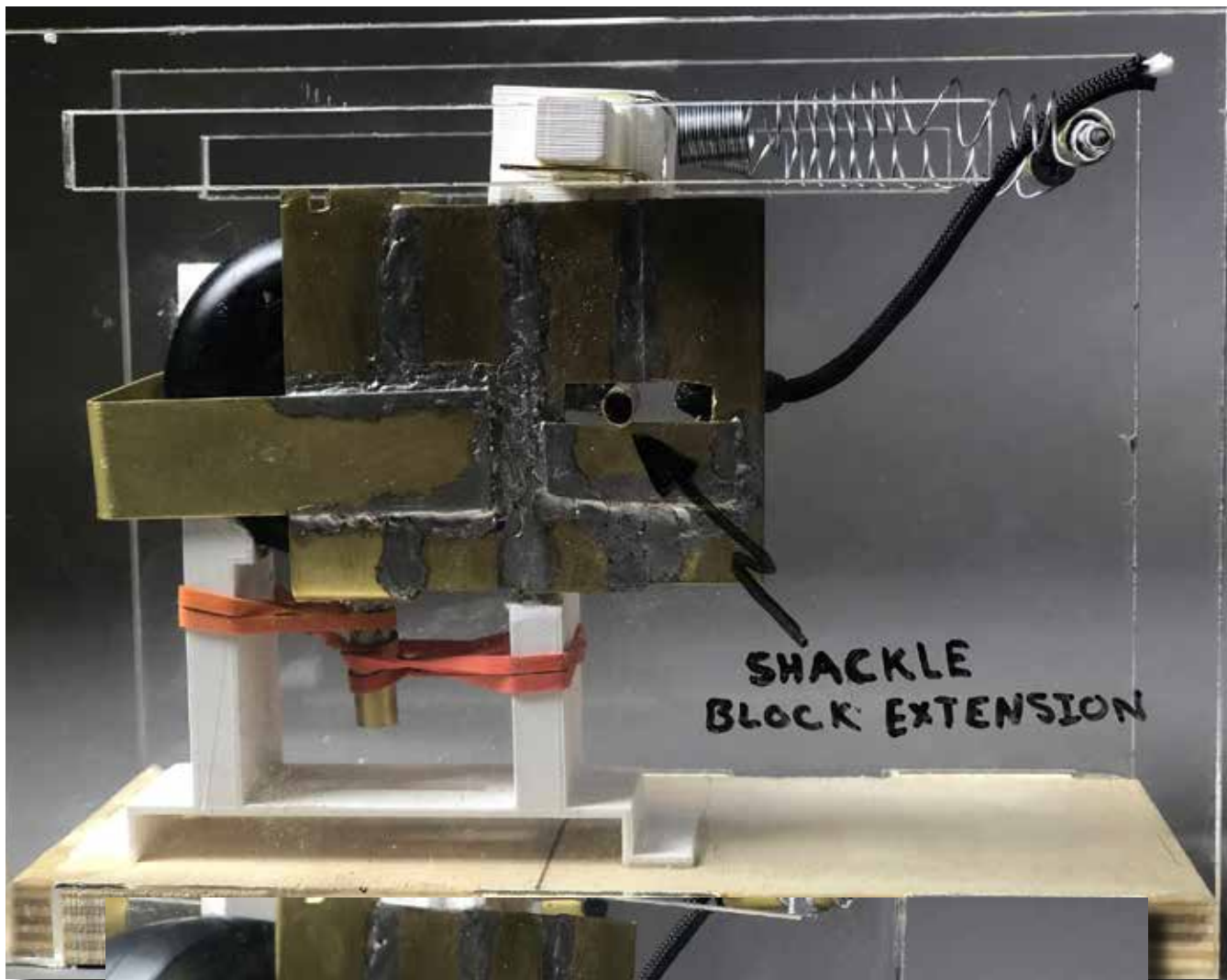

LOCKED

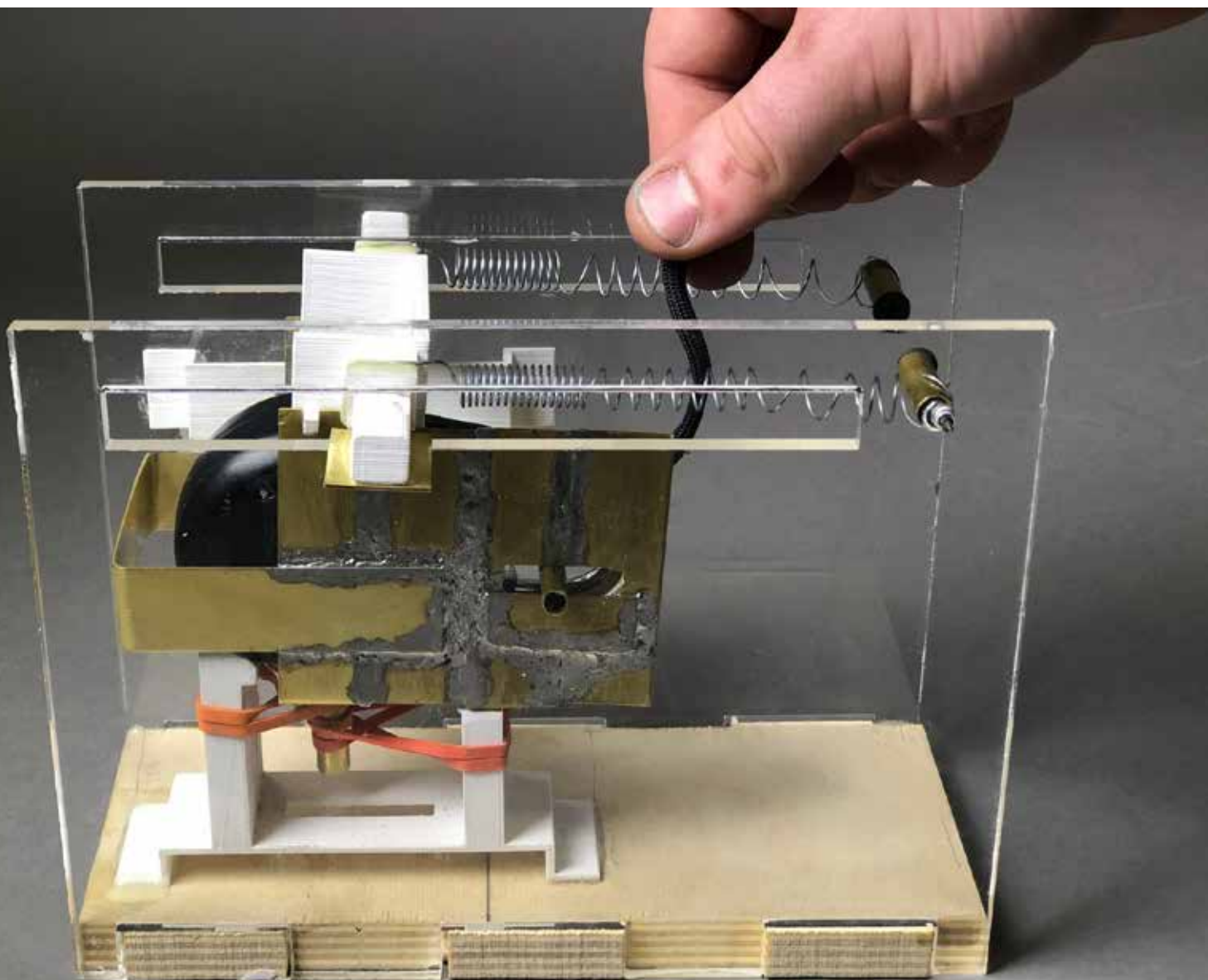

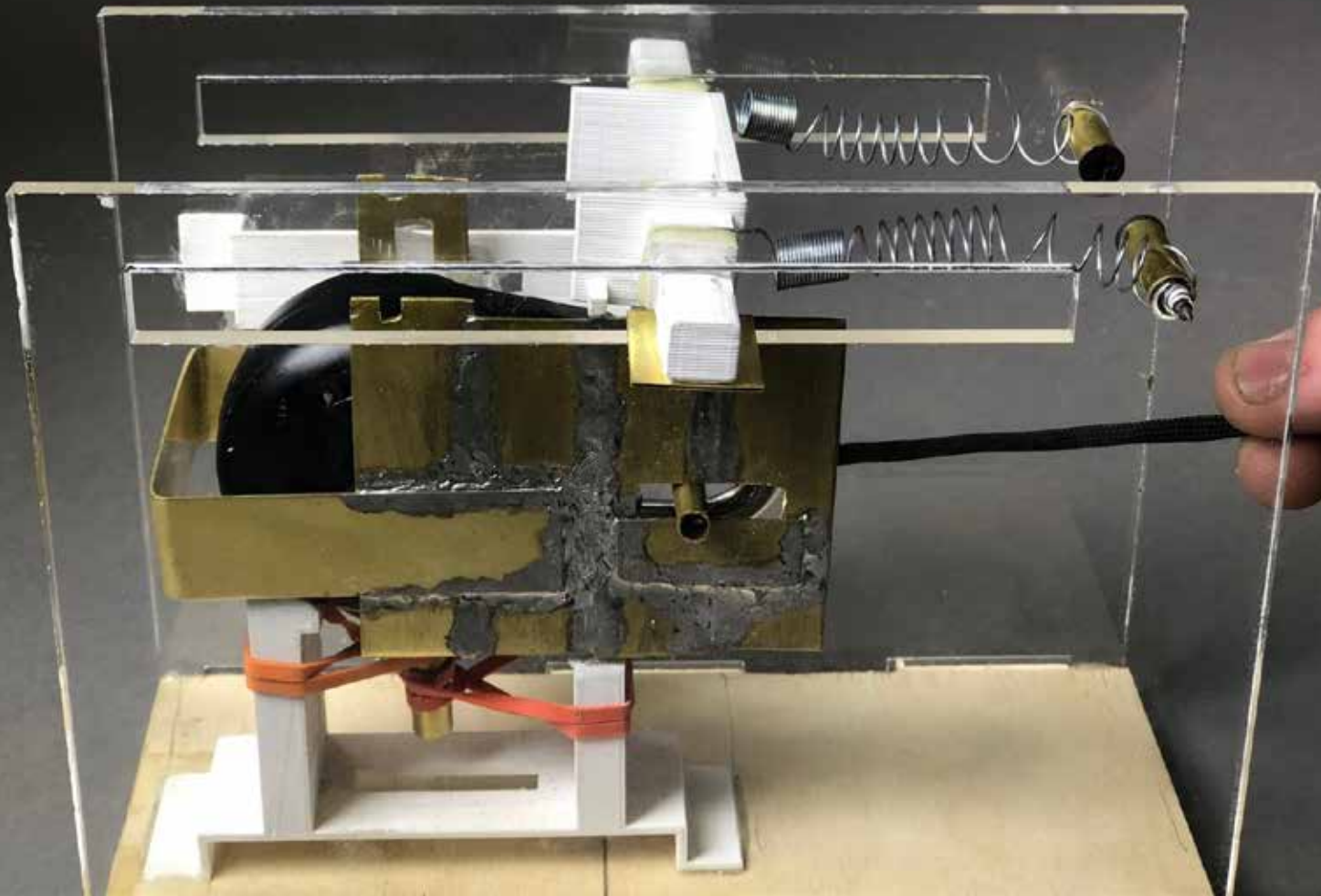

UNLOCKED

Materials/Manufacturing



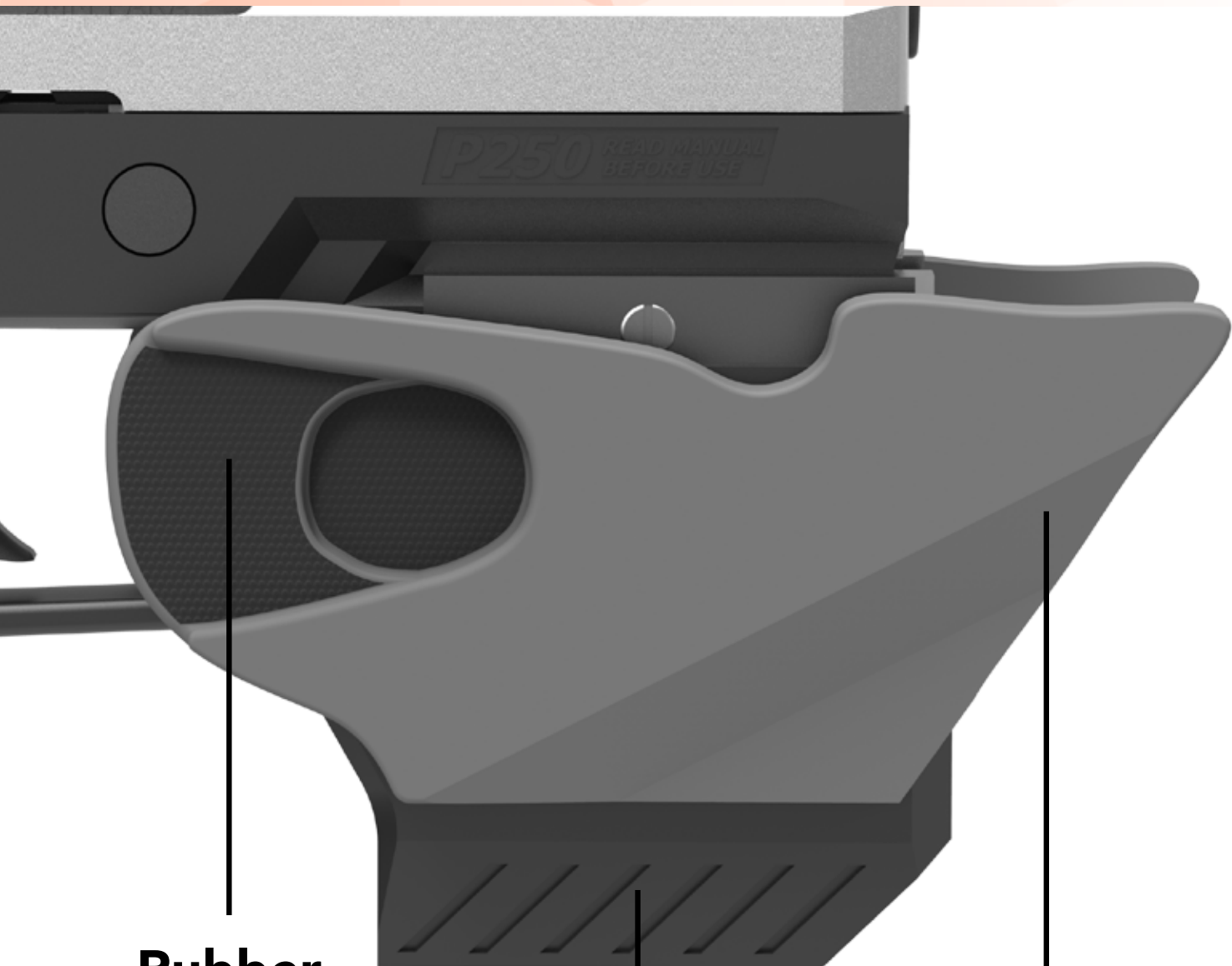

**Rubber
overmold**



**B390
aluminium body**



**Polymer
Tab**





Polymer is a composite material that consists of multiple similar bonds of materials that are interchangeable to make a strong lightweight material.

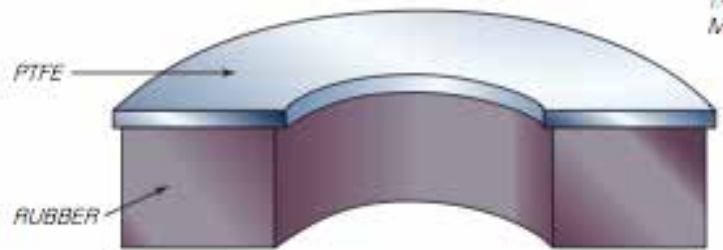
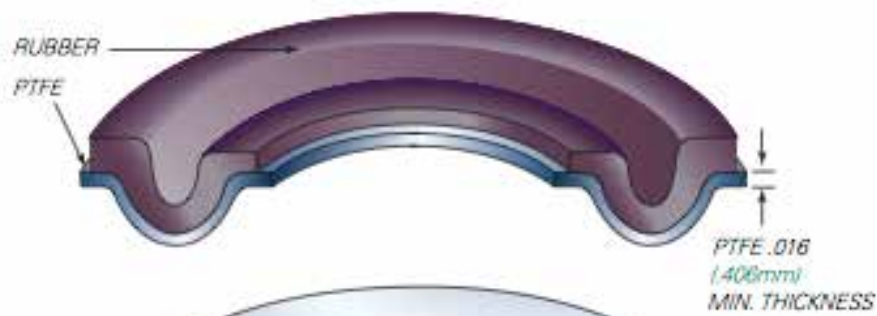

CRYOGENIC CLEANING
WILL BURNISH PTFE SURFACE

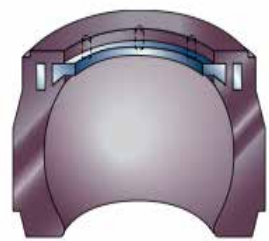

Mechanical Bond

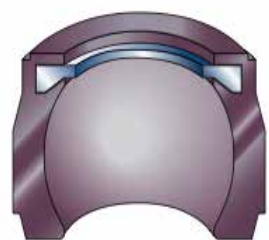

Chemical Bond

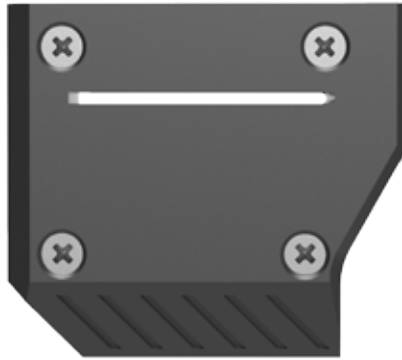

B390 is an aluminum alloy with high hardness and good wear resistance has great heat resistance capabilities. This alloy is suitable for many applications including internal combustion engine pistons and cylinder bodies for compressors and brakes.



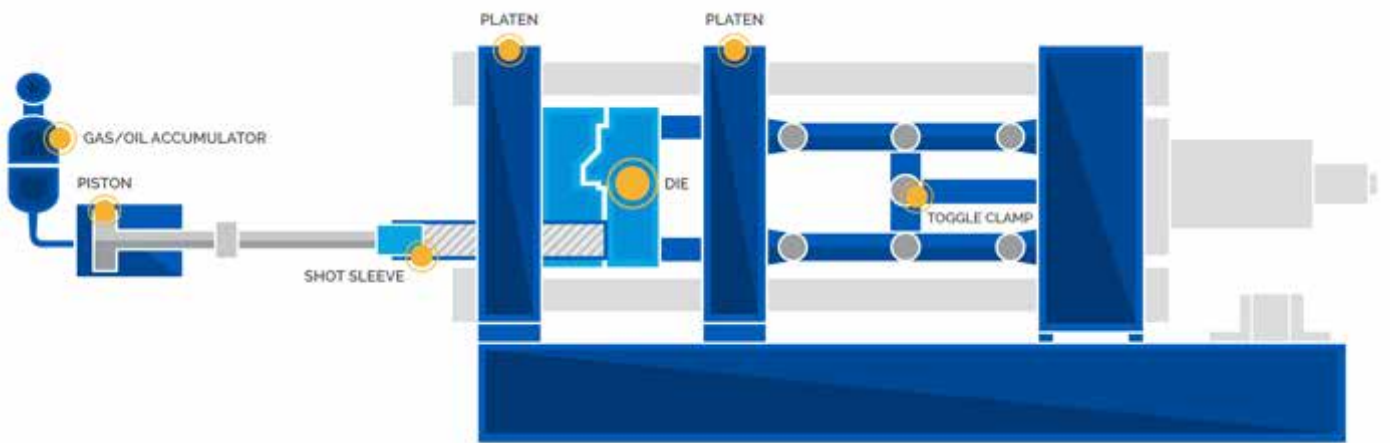

Cold chamber die casting is ideal for metals with high melting points and corrosive properties, like aluminum. Die casting tools last between 50,000 and 400,000 shots, depending on the application and class of the tool produced.

User Interactions

Here is a step by step of how the you user would attach guardlock to their pistol by sliding it on to the picatinny rail.

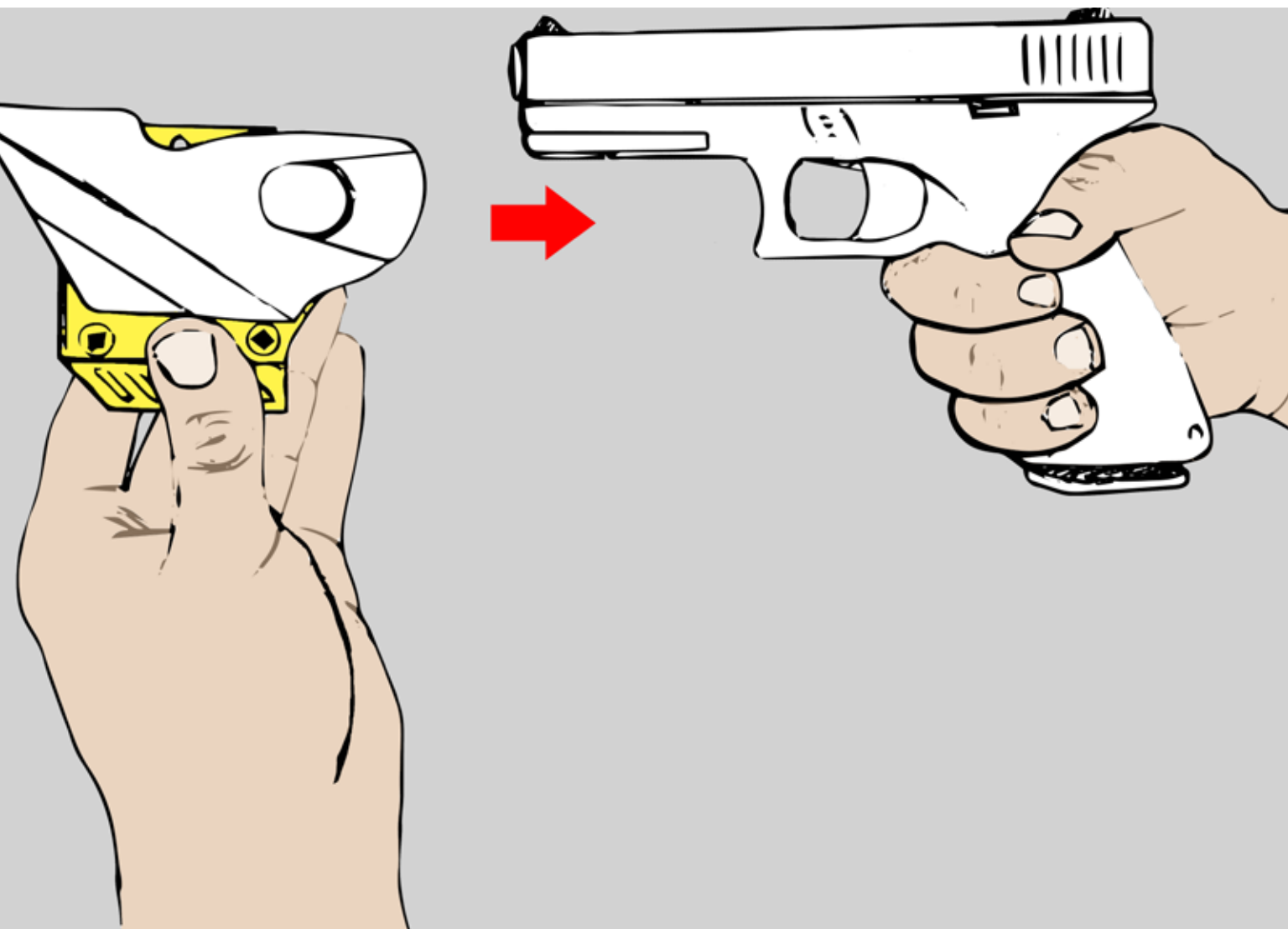

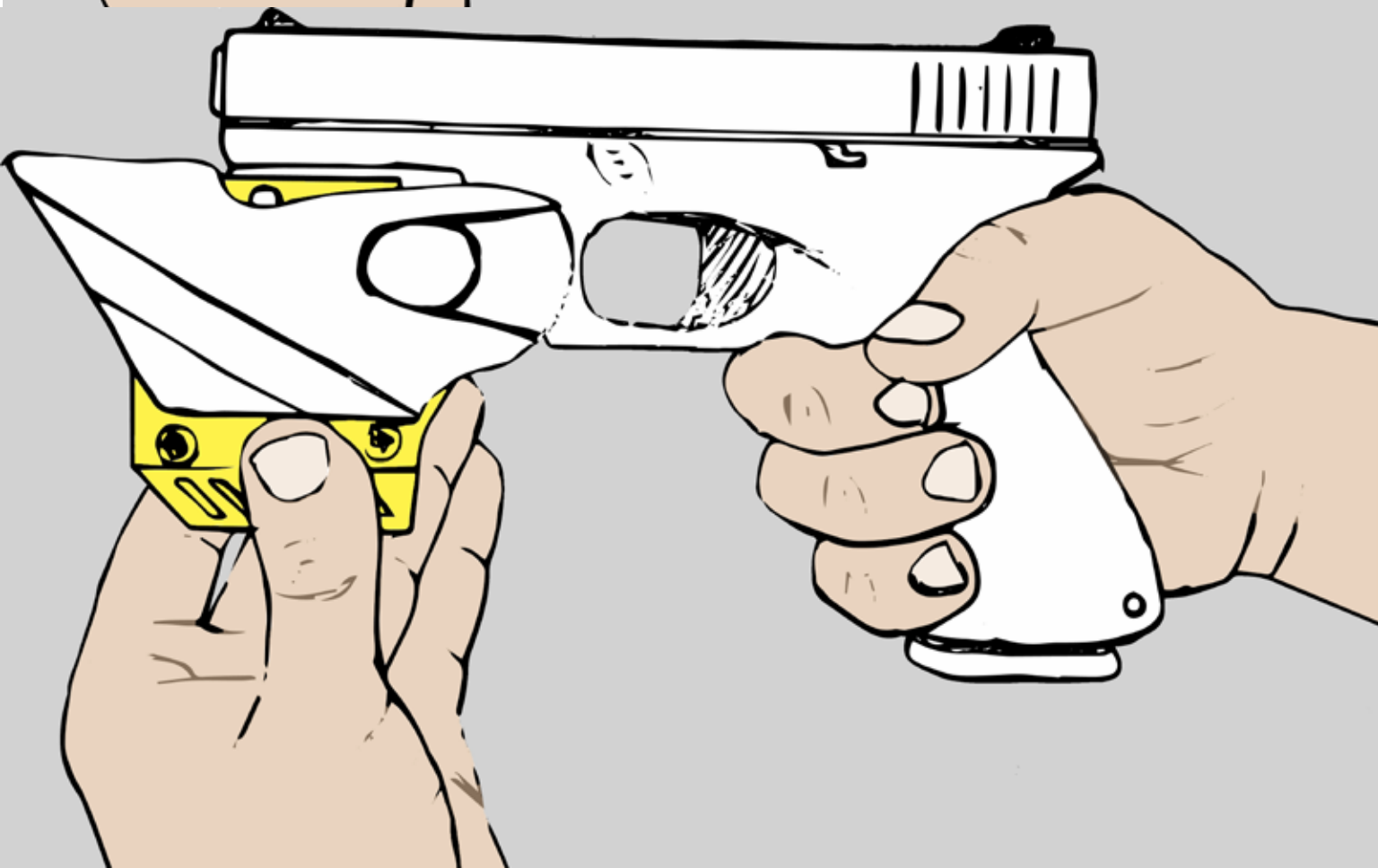
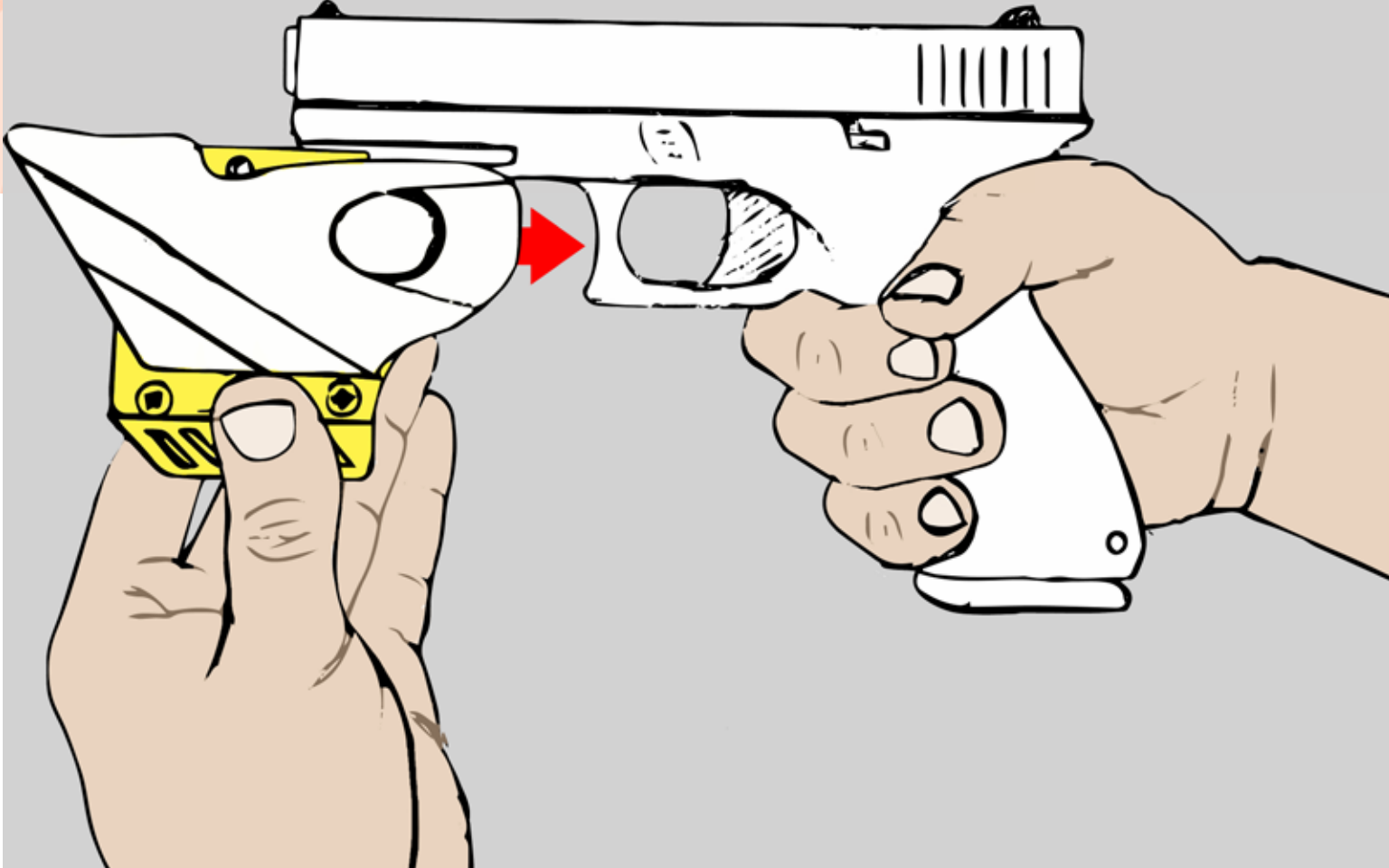

User Interactions

This is a step by step of how the you user would interact with guardlock to enter the directional code using the tabs to move in the corresponding sequence.

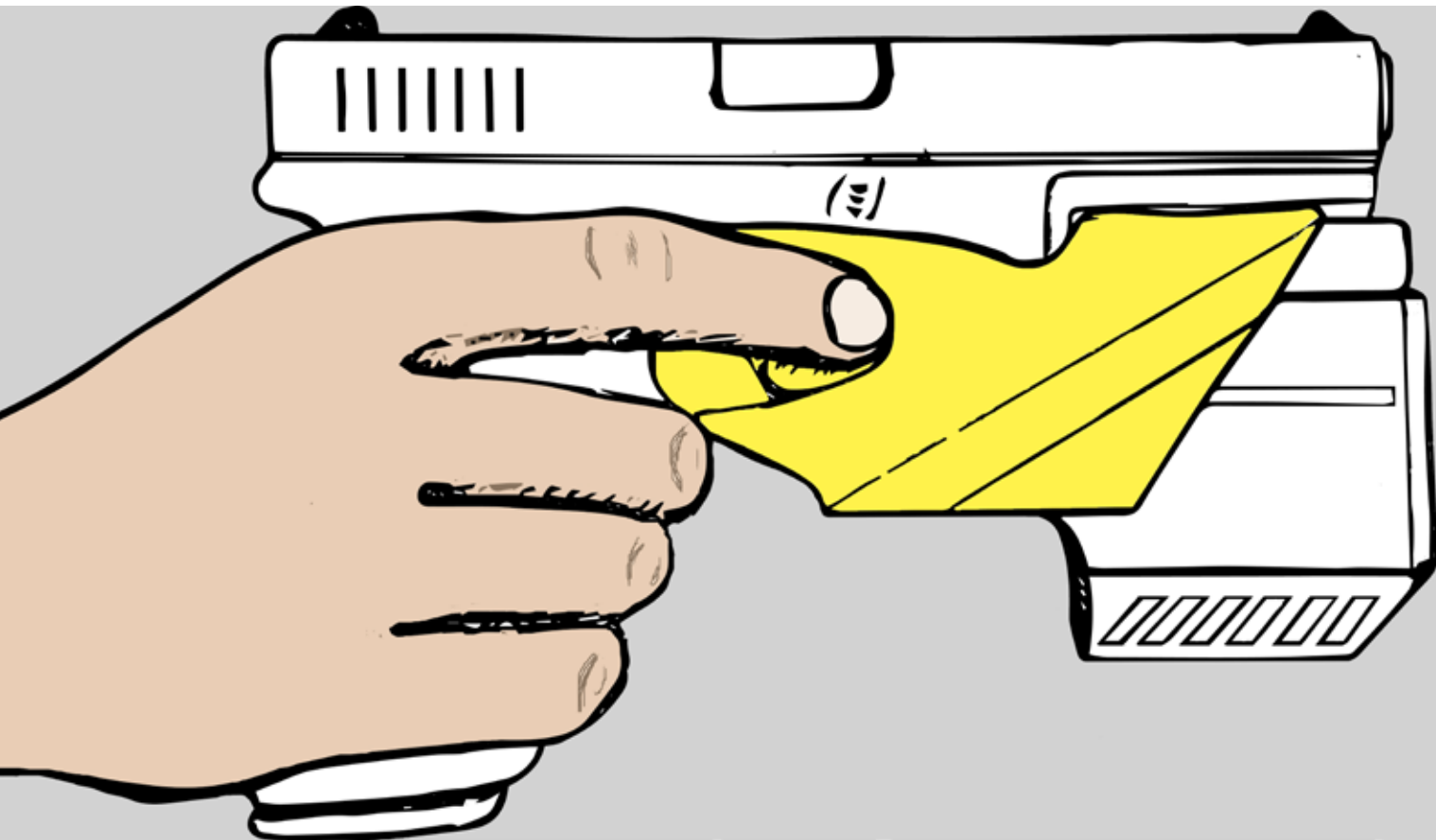

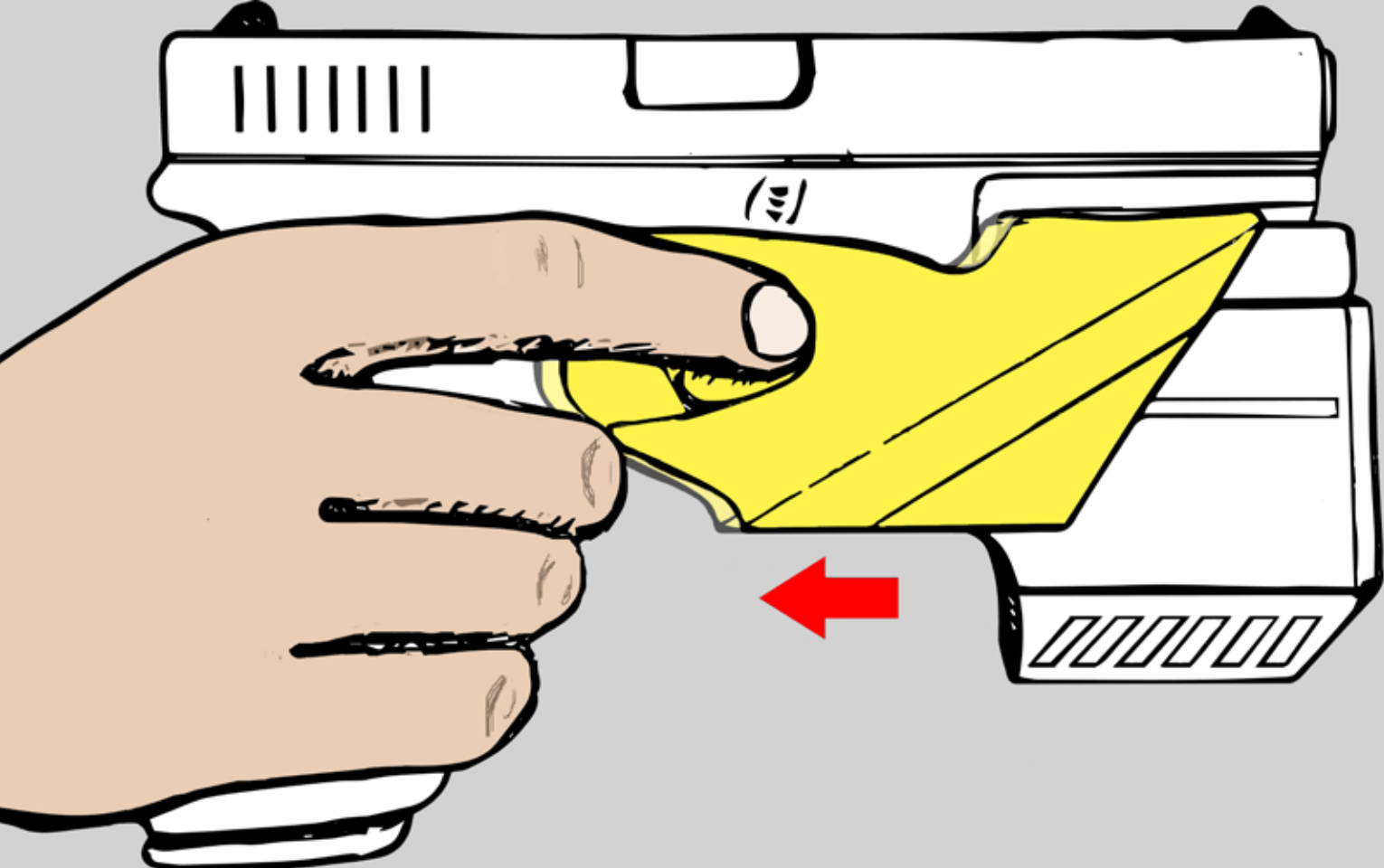
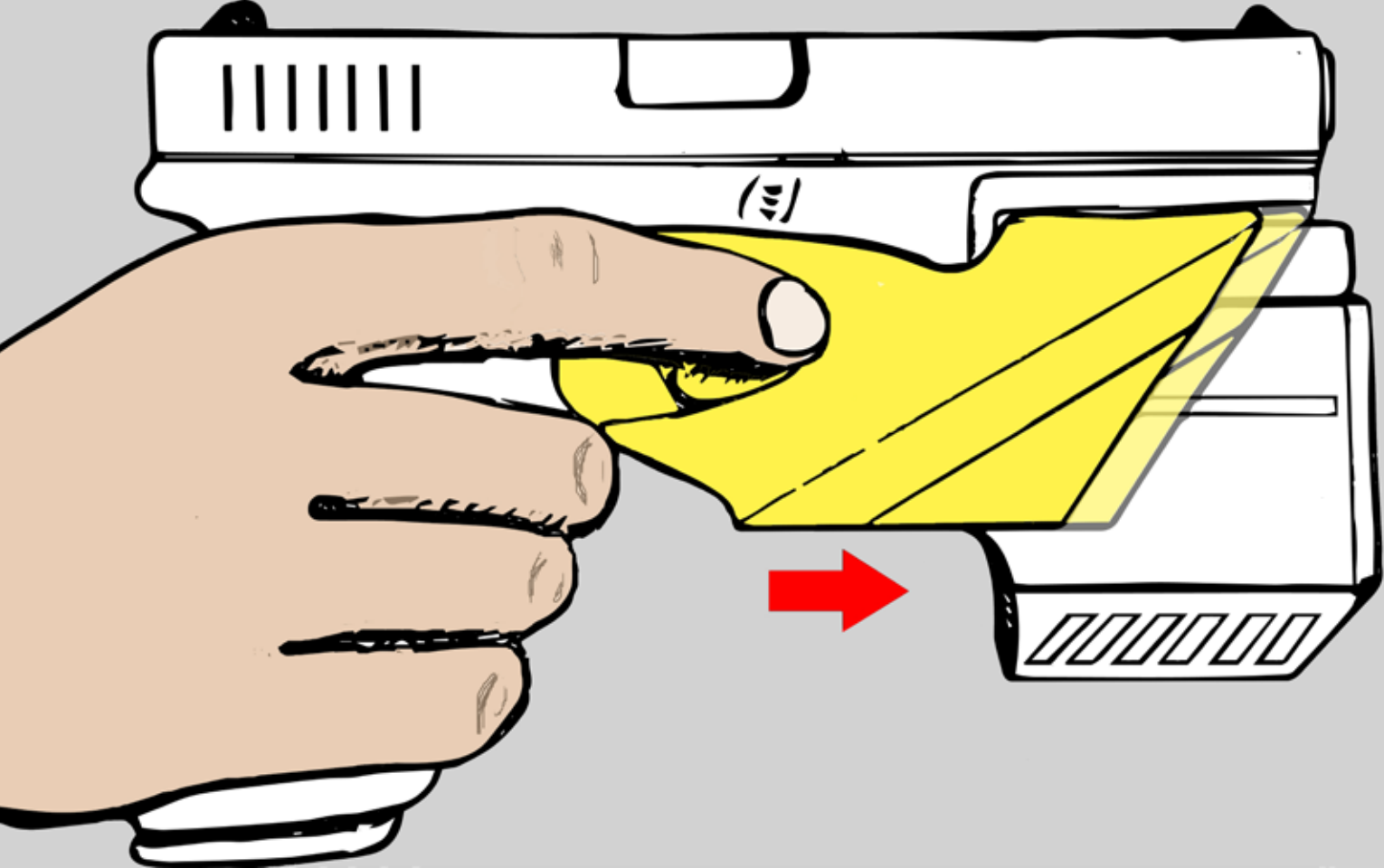



A vertical decorative strip on the left side of the page, featuring a complex geometric pattern of overlapping triangles and polygons in various shades of blue, ranging from light sky blue to a vibrant cerulean.

04

Final Model

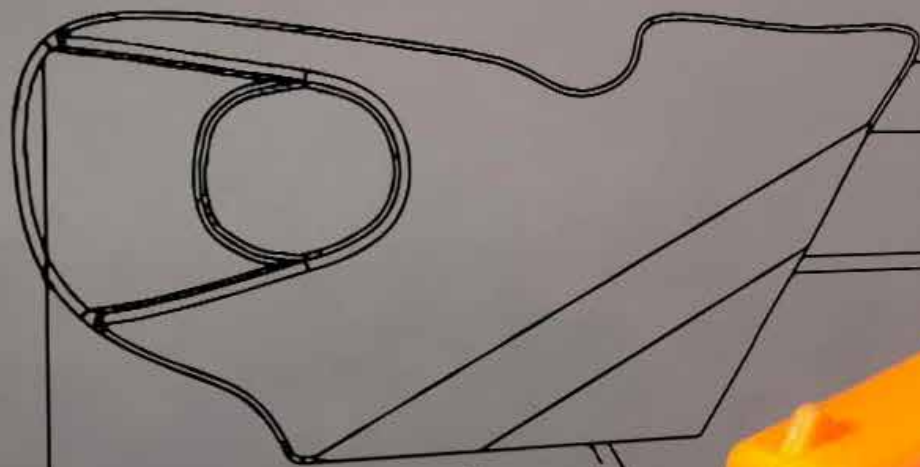

.333

Ø.120

.073

±0.1

.500

4.680



2.575

1.400

1.















LOCKED





UNLOCKED

THANK YOU
Mike Grosso & Joe Mooney