

2-2021

Callicore

Cole Miller

Thomas Jefferson University, cole.miller@students.jefferson.edu

Galen Ogg

Thomas Jefferson University, galen.ogg@students.jefferson.edu

Jasmine Phun

Thomas Jefferson University, jasmine.phun@students.jefferson.edu

Yajnesh Vedanaparti

Thomas Jefferson University, yajnesh.vedanaparti@students.jefferson.edu

Morgan Hutchinson, MD

Thomas Jefferson University, morgan.hutchinson@jefferson.edu

Follow this and additional works at: https://jdc.jefferson.edu/si_des_2023_phase1



Part of the [Industrial and Product Design Commons](#), and the [Pediatrics Commons](#)

[Let us know how access to this document benefits you](#)

Recommended Citation

Miller, Cole; Ogg, Galen; Phun, Jasmine; Vedanaparti, Yajnesh; and Hutchinson, MD, Morgan, "Callicore" (2021). *Phase 1*. Paper 6.

https://jdc.jefferson.edu/si_des_2023_phase1/6

This Article is brought to you for free and open access by the Jefferson Digital Commons. The Jefferson Digital Commons is a service of Thomas Jefferson University's [Center for Teaching and Learning \(CTL\)](#). The Commons is a showcase for Jefferson books and journals, peer-reviewed scholarly publications, unique historical collections from the University archives, and teaching tools. The Jefferson Digital Commons allows researchers and interested readers anywhere in the world to learn about and keep up to date with Jefferson scholarship. This article has been accepted for inclusion in Phase 1 by an authorized administrator of the Jefferson Digital Commons. For more information, please contact: JeffersonDigitalCommons@jefferson.edu.





80,000
Hip
Dysplasia

4,000
Femur
fractures





Seat gaps

Neck hyperflexion

Chest compression

Zielinski J, Oliver G, Sybesma J, Walter N, Atkinson P. Casting technique and restraint choice influence child safety during transport of body casted children subjected to a simulated frontal MVA. J Trauma. 2009 Jun;66(6):1653-65.



Point of View

User

Parents of
children in SPICA
casts

Need

Transport children
home from the
hospital

Insight

Safely
Comfortably
Affordably
Sanitarily

HOW MIGHT WE ...

transport children in SPICA casts in a *safe, comfortable, and convenient* manner so that the parents can feel more at ease.

Methods/Results: The Design Process

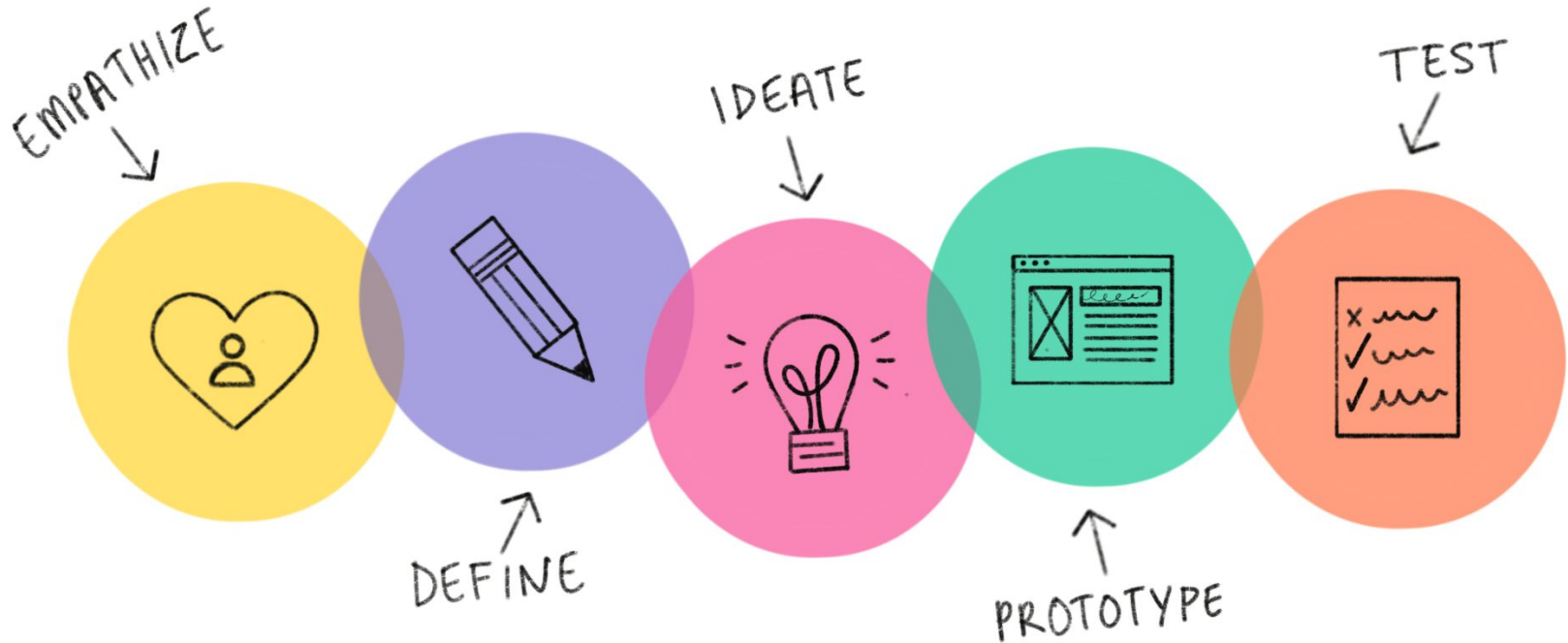

Methods: Empathize

Semi-structured
video interviews

12 parents

6 Injury Prevention
Coordinators

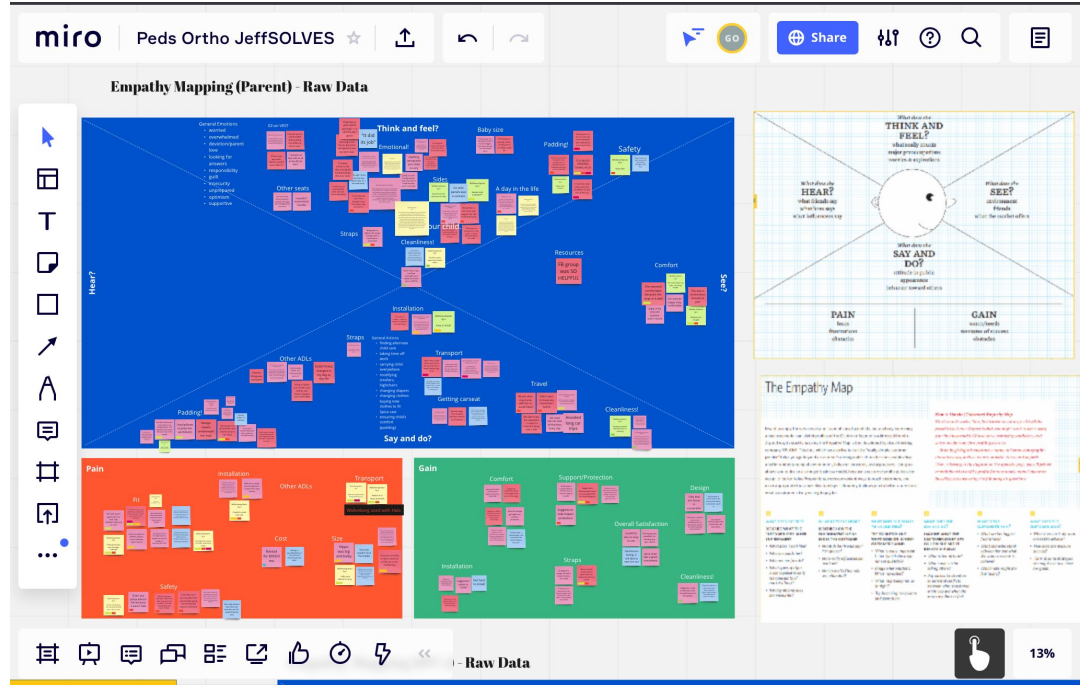

Methods: Define



Concept definition

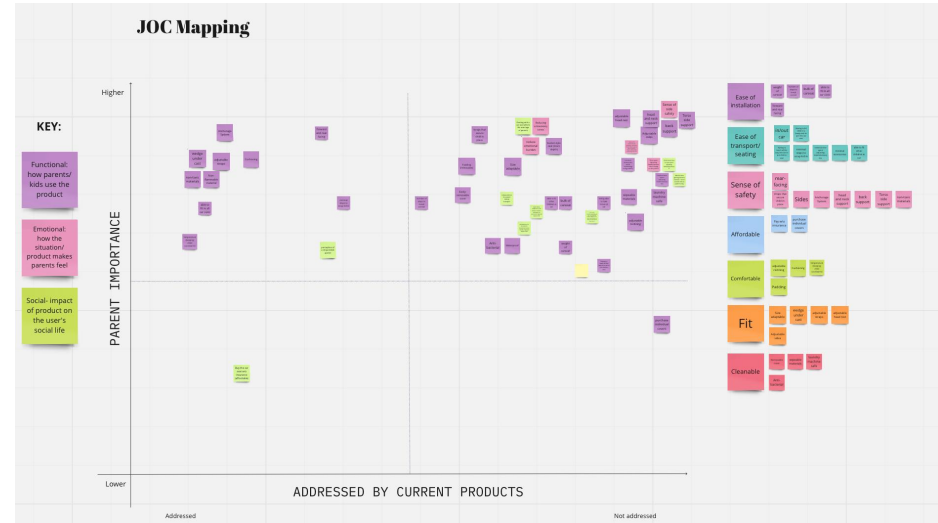

Concept prioritization

Methods: Ideate

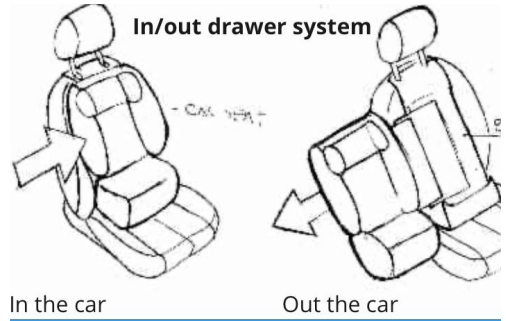
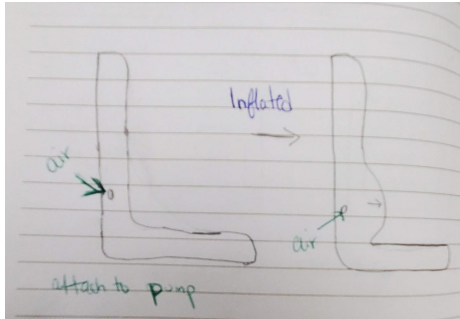
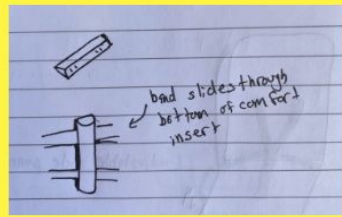
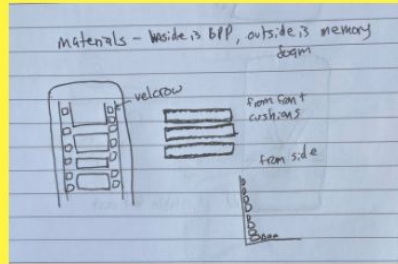
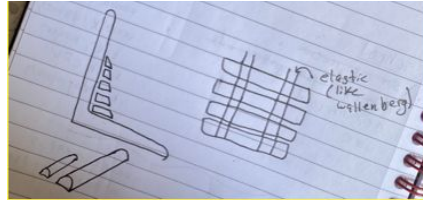
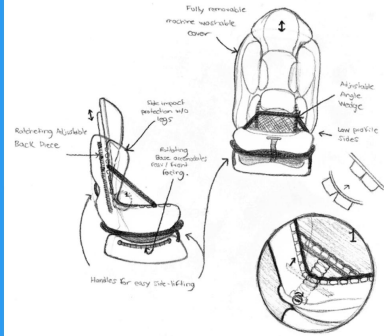
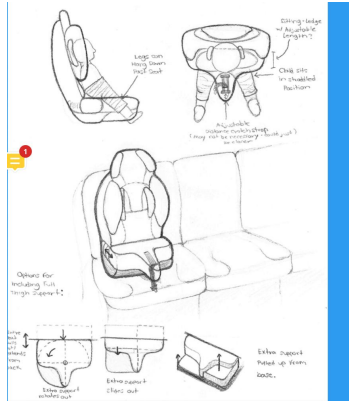

Adaptability

Methods: Prototype and Test





Adaptable

Expanding headrest accommodates for children between 6 months to 5 years



Wing Support

Wings allow for side impact protection without sacrificing fit, comfort, or ease of getting child into car seat.

Pommel Seat

Our pommel seat is our unique feature that fits the Callicore to the child, and not the other way around.



britax

Current gold standard?

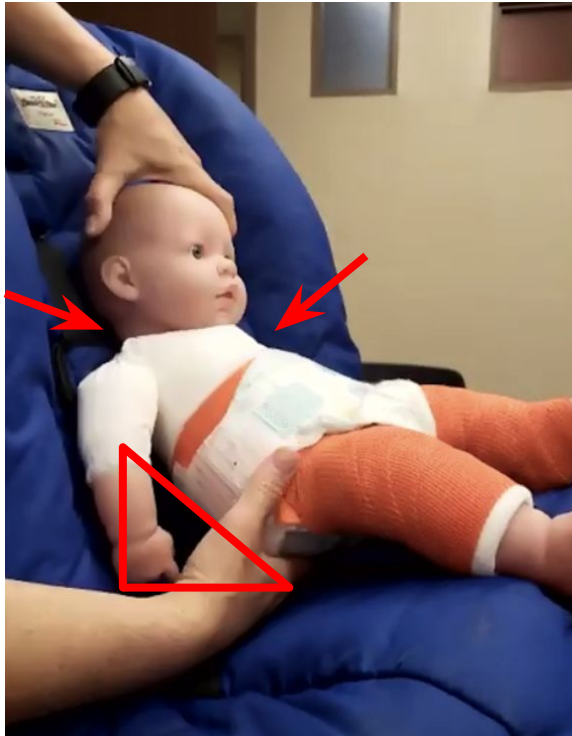

Callicore

Prototype testing





Testing the Adjustable leg supports...



Features

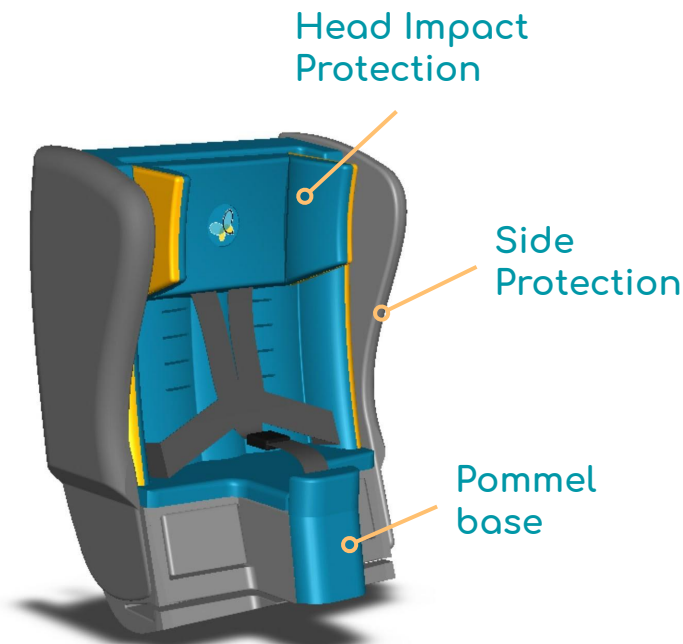

Neutral

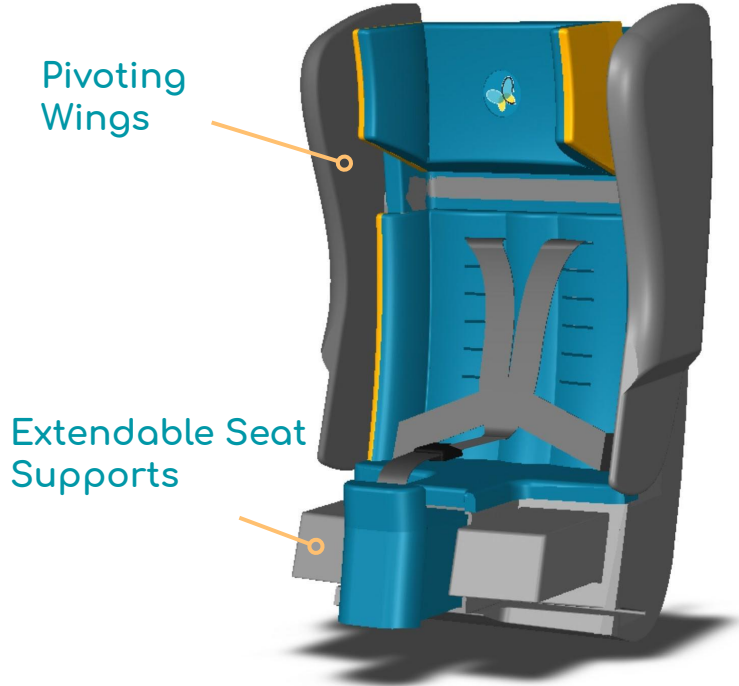

Extended

